

# The Drive and the Electrical Appliances in the Budapest Metro 120 Years ago

Dr. Péter Kádár – senior member of IEEE

Óbuda University, Kandó Kálmán Faculty of Electrical Engineering  
Power System Department, Budapest, Hungary  
Bécsi u. 94. Budapest H-1034 HUNGARY  
Phone: +36 209 447 241; fax: +30 1 250 0940  
kadar.peter@kvk.uni-obuda.hu

**Abstract** — The first electric underground in the continental Europe was inaugurated in 1896 in Budapest, Hungary. Werner Siemens planned an underground line in Berlin, Germany but the city leaders weren't convinced to do it that early. The driving force of the Budapest development was the World Expo of 1896, celebrating the Millennium of the Hungarians at the present day territory. The Hungarian industry was developed enough to build the "hardware" (rails, tunnel and carriages), but the new electric drives arrived from Germany. So the ready-made solution and the unbelievably efficient "project management" allowed the realization of the project in a 20 month time range and the project even managed to stay within budget.

The 20 carriages were fabricated by Hungarian companies while the drives by the German Siemens & Halske Co. Only 5 carriages remained from the old relics. In this paper the 120 year old electrical parts and solutions are introduced from details of the original electrical plans and the photos about the main electrical appliances of the 2 carriages to be found in the Budapest Underground Museum. The current collector, the breaker, controller switch box, lighting, signaling and safety devices are discussed in detail. The power supply plant is shown in its ancient and present form, as well.

This product is an early example of a smooth industrial cooperation among German – Austro-Hungarian inter-multinational companies, still two decades before World War I. It is also interesting that the structure of tram/train/underground technology was already developed to 100 %. Nowadays we have the same structural elements – of course – made of high(er) tech materials and optimized to their shape and size.

**Keywords:** *underground, electrical appliances, drive*

## I. INTRODUCTION

65 years after Stevenson's first locomotive test in 1814 the electric urban rail transportation was demonstrated by Werner Siemens in 1879. In 1896 was inaugurated the European-continent's first electrically driven underground tram – the Budapest Metro. It was made by international cooperation where the electric parts were manufactured by Siemens & Halske Co. and the carriages were fabricated by Hungarian companies. One of the most important statement that the main functions and elements of the tramway system were developed also 120 years ago and used today in the

same manner. These are the current collector, motor, controller, brakes, lighting, alarm system, signalization, overhead-line power supply, etc. In the followings we walk through the main parts of the underground system. Good luck, two of the 20 original 120 years old carriages are restored and exhibited in the Underground Railway Museum (URM) in Budapest, Hungary.

## II. THE DRIVES

It was strange but useful and competitive practice that from the first moment two sets (10 wooden covered and 10 covered) carriages ran on the rails. The two competitive vendors had similar, but not identical solutions to carriage structure, motors, current collectors, etc.

In 1933 the voltage of the system supply was raised from 350 V to 550 V, so the motors, switches and lighting system was changed.

The first set (No. 1-10) was mounted with 2 x 12 kW Siemens LDo type motors and flat controllers. These bogies contained a Gall-chain drive between the motor and the wheel. It was broken many times. The second set (No. 11-19 and royal carriage) was mounted „S” type cylinder controller and these got a direct drive (2 x 15 kW B22/30 type) where the rotor shaft was identical with the main wheel axle of the carriage. All had electrical and mechanical breaks, too.

In the years of the thirties the electrical drives were upgraded. The bogies, the suspension were redesigned to double spring system (spiral and flat). All the carriages No. 1-10 got 2 x 44 kW Ganz TR 4,5/14 type motors (produced by Hungarian BBC), „SS-907” type cylinder controller and airbrakes for the pulled carriages.[1]

At the beginning only spiral resistors were used for the dissipation of the power of electrical braking of DC motors. In 1936 the breaking system was extended by energy-feed-back mode, so a part of the kinetic energy was recuperated and also the heating power of the tunnel was decreased.

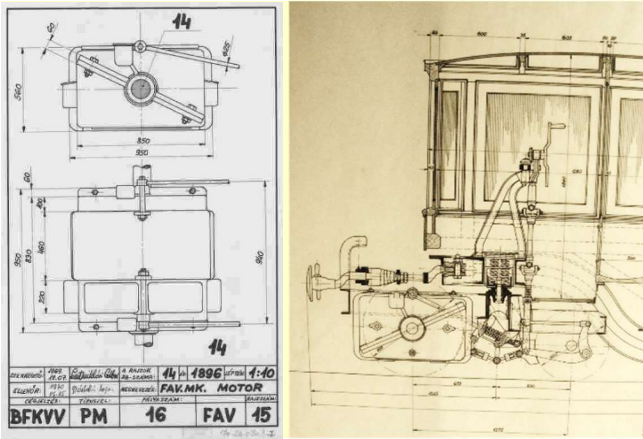

Fig. 1.: Views of direct shaft motor block [2]

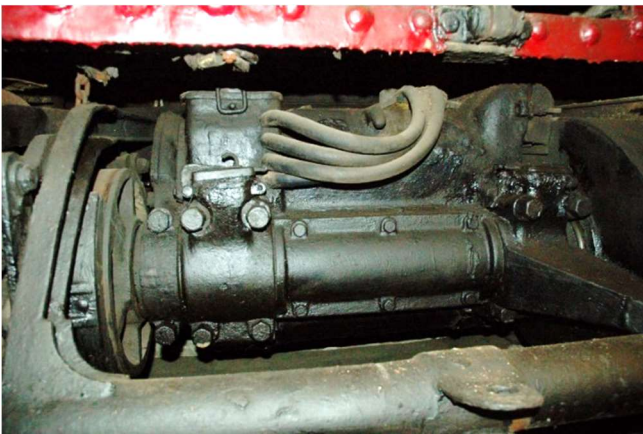

Fig. 2.: The motor block in carriage No.19. (URM)

### III. THE CONTROLLER

One of the most crucial elements of the urban electric carriages is the controller that switches million times per decades. In the most widely used solution the sliding contacts are installed on a cylinder shape holder. The lay out sketch of the controller was a decisive part of the electrical circuit diagrams during hundred years. The controllers play a role in case of starting (acceleration), normal cruise mode, electrical braking and direction change, as well. The early controllers switched directly the motor current.

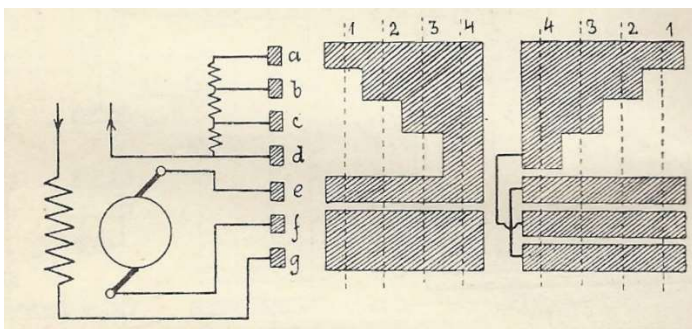

Fig. 3.: Plain sketch of an electric motor controller from a textbook of 1910 [3]

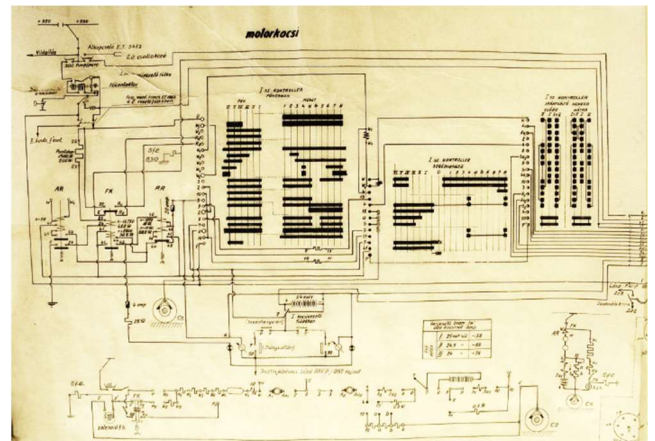

Fig. 4.: Siemens SS-907 controller's circuit diagram from a condition survey from 1958 [2]

At the beginning simple flat (dial) controllers, later Siemens-Halske SH 902, Siemens-Schuckert SS 907 and BSzKRt type controllers were utilized in the underground. The same controller types were later used also in the urban trams.[4]



Fig. 5.: Siemens" (Siemens-Schuckert SS 907) [5]



Fig. 6.: „BSzKRt” type controller from the thirties in the carriage No.19 in the URM

#### IV. THE LIGHTING

In the years 1880 the petroleum lighting spread over for the railway carriage illumination, e.g. Root's and Hannay's solution. [6]

The fact that electricity was used also for the illumination of all stations and carriages of the underground was appreciated in 1896.

It was Edison and the English Swan who invented carbon filament light bulbs in 1879. However, Edison had better marketing, that is why only his name is mentioned nowadays. There was even a court trial on the patent rights. Swan was in a better position, in the end they reached an agreement out of court and the bulbs were sold under the name Ediswan with a so called Swan bayonet-joint base. The Ganz factory preferred the Swan base, it bought the bulbs and manufactured their bases. These bases withstand vibrations in the vehicles, even today cars have bayonet-joint bases.

Carbon filaments were not really fragile. Bamboo fibers were bent to the required shape and they were carbonized in an environment without oxygen. The fragile and uneven filaments were homogenized and ignited in carbon-hydrogen gas. Where the fiber was thinner it started to glow due to larger resistance and there carbon was condensed. The end result was a strong homogeneous filament. The long filament was flexible enough and resistant to minor shocks.

Swan used nitrocellulose, that was the first synthetic fiber. The first energy saving wolfram light bulbs (Egyesült Izzó, Just és Hanaman 1905), produced by chemical metal aggregation were much more sensitive to vibrations. This defect was compensated in 1910 by the various filaments

(powder metallurgy, forged and pulled) created by the American Coolidge.

Edison light bulbs debuted on the European continent at the Paris International Electrotechnical Fair in 1881, and in Budapest just one year later, in 1882.

City trams and the underground initially operated with 350 V DC. It was used for lighting too. In the underground 4 pieces of 86 Volt carbon filament light bulbs were connected serially [16]. Later on the voltage was increased to 550V, then 5 pieces 110 V light bulbs were connected.

From the cab a 12 V battery supplied the energy for emergency lighting purposes. Also the plug-in fuses were installed in the cab.

Meanwhile at the Hungarian Railway Company (MÁV), the more expensive carriages were equipped with Dissous gas lamps, with Auer gas mantle. They were in use even in the 1950's.

However, the court train of Emperor Franz Joseph had electricity already in the 1890's. It had carbon fibre light bulbs, but the batteries had to be charged or replaced at each larger station. [7]



Fig. 7.: Advertisement of carbon filament bulbs from 1910 [3]



Fig. 8.: Tungsten filament lampholder's cross section from the 30-ies [2] – lamps in a tram [8] – lamp in the URM

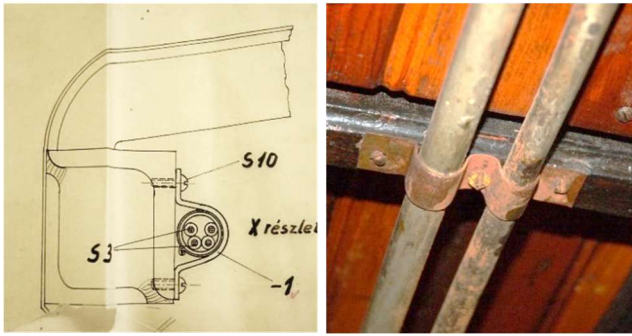

Fig. 9.: Tubbed cables plan [2] and reality (URM)

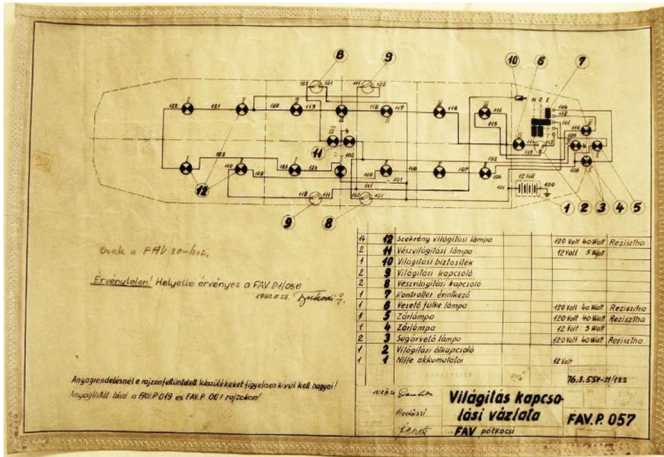

Fig. 10.: Scheme about the series related lamps (5 x 110 V = 550 V) [2]

The first guarding system was produced by Siemens-Halske, the most modern light signaling system in that age. The carriage leaving the station set the pilot light red by a mechanical switch, meaning „The tunnel is occupied”. After the carriage left the next station the white lamp lit up „The tunnel is vacant”. The green light meant „Slowly”. In case of an electrical failure the platform guards communicated by telephone.

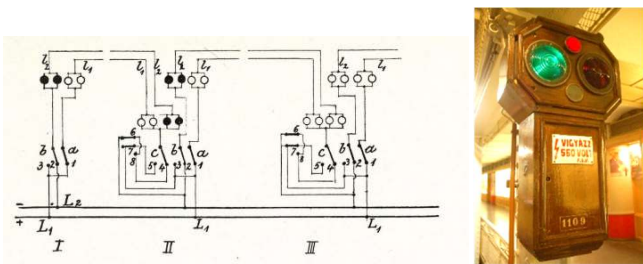

Fig. 11.: Circuit diagram of the signalisation system and the signaling lamp [9]

For the internal signaling the mechanical signal alarm was used (a long rod operated a signal switch in the cab). A direct switch was also available for the passengers to break the electrical current. From the thirties the driver had a loudspeaker to inform the riders.



Fig. 12.: Alarm rod – emergency breaker – loudspeaker (URM)

V. THE UPPER WIRES AND THE CURRENT COLLECTOR

In the first sketch of the carriages, three upper rails appeared. However, the small tunnel height (2.9m) was a problem. Finally, the middle of the carriage (cabin) was „pushed down” close to the rails between the bogies. It was called „swan neck”. The current collector “gate” was also “squeezed” into a 15 cm gap between the tunnel ceiling and the upper desktop. [10]

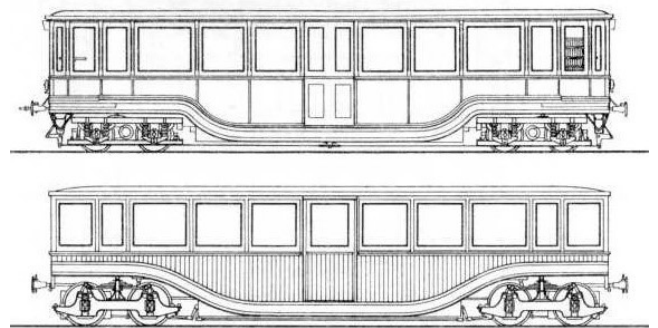

Fig. 13.: The „Swan neck” carriages: No. 1-10 – metal covered, No.11-19 – wood covered [11]

In the early period the two feeding poles were made by a double upper iron rail (50 mm height, mine rails). Wooden cubes served as insulator-holders of current conductor rails. Later it was changed into a single upper rail and the rail below was used as feed-back pole. At the wooden covered carriage a special early pantograph collector was applied. At the metal cars a spring in a tube pulled up the collector to the double upper feeding lines. At the point where the feeding cable entered the carriage-body a spark-gap arrested the high voltage impulses.



Fig. 14.: The double pole feeding rails with wooden insulator-holder (URM)



Fig. 15.: Sliding contact and wooden insulators and spark-gap at the entry to the carriage-body (URM)

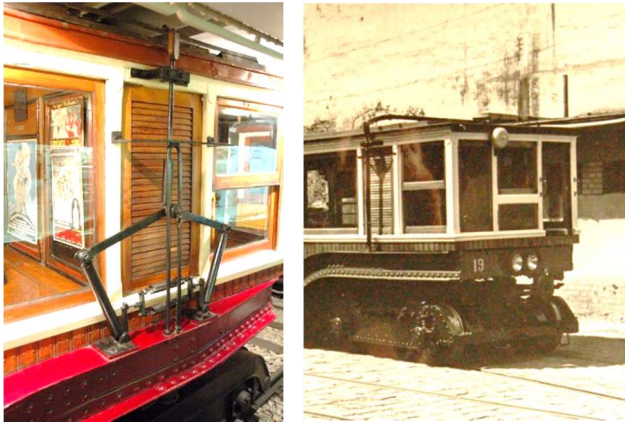

Fig. 16.: The pantograph (URM) and the „spring-in-tube” type collector in operation in 1951 [8]

The wain house was located some hundred meters distance from the terminal of the underground line. Between the terminal and the wain a „lower, underground” collector system was laid. A special small size current-collector-carriage was connected to the underground carriage for these some hundred meters and its own drive could be used for housing. After the Second World War a normal tram overhead line was deployed in this section. In the tunnel the upper wire was put 2.9 m high because the niveau difference between the overhead street surface and the tunnel was only 3.25 m. The typical heights of tram overhead lines in the city are 4,5 - 5,5 m. The underground current collector was not tall enough to reach the open-air wires. Here a small electric locomotive was used for housing or another small locomotive was used as „current collector”. [12]

There were also some plans to use independent locomotives in the tunnel with simple passenger cars by the company Schlick.

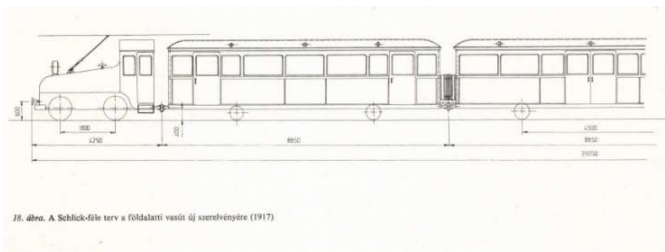

Fig. 17.: The idea of the external locomotive (Schlick, 1917) [9]

## VI. THE POWER PLANT

In 1888 for the supply of three tram lines a power plant was built in Kertész street. It had two 120 HP steam engines, the trams were fed by 300-400 V DC.

The two pole overhead wires of the underground were fed from this power plant in Kertész street. The existing facility was extended by 4 units of 268 m<sup>2</sup> boilers, 2 pieces of 600 HP compound steam engine and a Siemens DC generator. The total output was 700 kW on 320 V DC. [13]

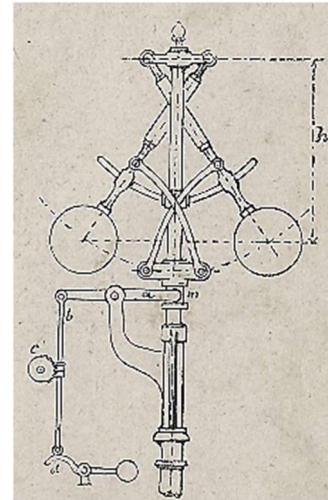
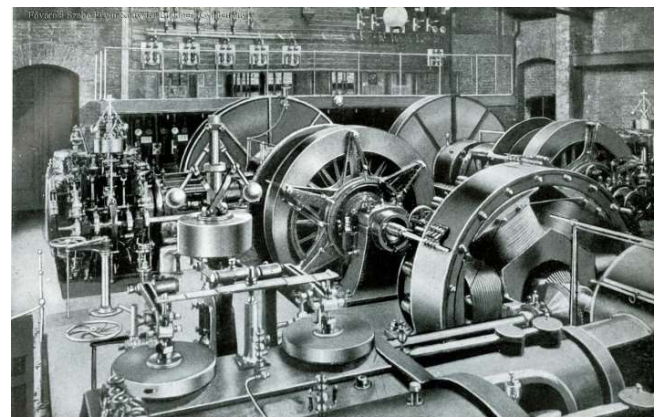

Fig. 18.: Centrifugal governor for steam engine speed regulation in a textbook from 1897 [14]



A BVVV Kertész-utcai áramfejlesztő telepének gépüzem 1897-ben (Négy, egyenként 200 lóerős gőzgéppel)

Fig. 19.: Engine room of BVVV - Budapesti Villamos Városi Vasút Rt. (Budapest Electric Urban Train) in Kertész street with 4 x 200 HP steam engine, 1897 – centrifugal governor in the middle [15]

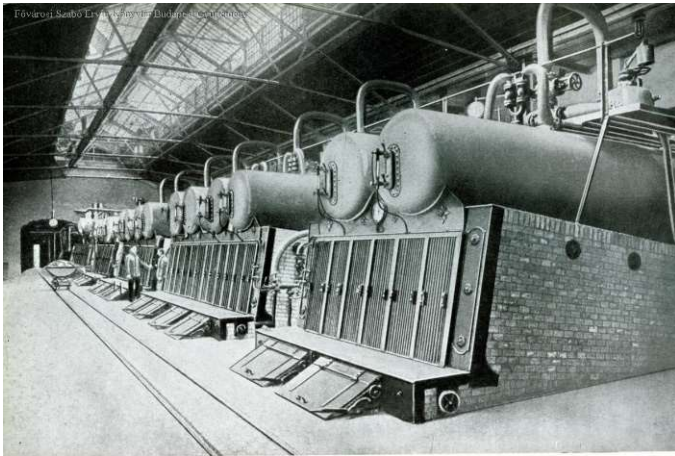

Fig. 20.: Boiler room of BVVV - Budapesti Villamos Városi Vasút Rt. (Budapest Electric Urban Train) in Kertész street, 1897 [15]



Fig. 21.: The old power house – today [17]

## VII. CONCLUSION

The first commercial electrified Budapest underground contains all the functions and elements of modern metro systems. The design and the quality of the materials made available to use the systems for long decades with overhauls but without fundamental changes. This solution is a flagship of the good old days of the pre-semiconductor-age.

This artifact is a human-friendly technology (size, speed, appearance) so to save for the future is our common task. The Budapest metro is a candidate for becoming an IEEE milestone.

## VIII. ACKNOWLEDGEMENT

I wish to express my special thanks to Miklós Merczi Head of Department, Hungarian Museum of Technics and Transport for making available the access to archives; to Sandor Jeszenszky providing information about old lighting equipment; to heirs of János Nemeth, for providing archive

photos and manuscripts and finally to Ildiko Kelemen for linguistic support.

## IX. REFERENCES

- [1] P. Istvánfi: A FAV régi kocsijai (The old carriages of the Budapest Underground; [www.villamosok.hu/metro/jarmu/favold/favold.html](http://www.villamosok.hu/metro/jarmu/favold/favold.html))
- [2] Archive of the Transport Museum
- [3] Mezey Bertalan: Elektromotorok szerkezete, működése, kapcsolása és kezelése (Electric motors: Structure & operation); Thália Kö- és Könyvnyomdai Műintézet, Budapest, 1910
- [4] Németh Zoltán Ádám: A BVVV G és K típusú motorkocsijai (G and K type locomotor) <http://villamosok.hu/nza/26002800.html>
- [5] Transport Museum, Budapest - <http://hampage.hu/trams/fav/>
- [6] Magyar Mérnök- és Építész-Egylet Közlöny, 1887; (Gazette of Hungarian Engineers and Architects) By Gabor Berszán in <http://www.berszangabor.hu/a-human/15-hum/t10-01.htm>
- [7] Sandor Jeszenszky: The history of the electrotechnics, manuscript, 2017
- [8] Németh János: The tram fleet of Budapest in 1951, manuscript
- [9] Medveczky Ágnes: A millenniumi Földalatti Vasút (The Budapest Underground Train); Közlekedési Dokumentációs Vállalat, Budapest, 1975
- [10] A Millenniumi Földalatti vasút rövid története (Short history of the Budapest Underground) Villanszerelők lapja, 2009 október
- [11] <http://villamosok.hu/metro/jarmu/favold>
- [12] Varga Ákos Endre: Lost rails in Budapest <http://hampage.hu/trams/fav/>
- [13] Sali Emil: Budapest közműrendszerei (Infrastructure of Budapest) EPA Budapesti Negyed 22. (1998/4)
- [14] Edelmann Sebő: A gőzkazán és Gőzgép-üzem kézikönyve (Manual of steam boilers and engines); Szombathely, 1897.
- [15] Archive of Budapest Szabó Ervin Library
- [16] Németh János: History of Royal carriage No. 20. Budapest in 1965, manuscript
- [17] Benda György, Fehes Balázs: [villamosok.hu](http://villamosok.hu)

The non marked photos are made by the author.