

The History of Liquid-Crystal Display and Its Industry

Hirohisa Kawamoto

Nara City, Nara 631-0006 Japan (email:kawamoto@zc4.so-net.ne.jp)

Abstract — Liquid-crystal display (LCD) was invented in 1964 at RCA Laboratories in Princeton, NJ. In 1970, twisted-nematic (TN) mode of operation was discovered, which gave LCD the first commercial success. The LCD manufacturers supplied small-size displays to portable products such as digital watches and pocket calculators. In 1988, Sharp Corporation demonstrated a 14-in. active-matrix full-color full-motion display using a TFT (thin-film-transistor) array. Observing this, Japan launched a true LCD industry. Large-size displays were first supplied to personal computers and then to television receivers. In the second half of 1990s, the industry has moved to Korea and Taiwan.

Index Terms — Active Matrix, Fluorinated Liquid-Crystals, Heilmeyer, Helfrich, IPS, Sharp, TN Mode.

I. INTRODUCTION

Back in 1970, I was with RCA David Sarnoff Research Center, where a liquid-crystal display had been invented. In 1985, I joined Sharp Corporation in Japan, where I witnessed major development efforts at its Tenri Advanced Development Center. In Sharp, I participated in founding the European Laboratory at Oxford in England, where I met Peter Raynes, who had played a key role in the development of the first stable and practical liquid crystals, cyanobiphenyls, at Royal Radar Establishment (RRE). Through him, I became to know European scientists who had made important discoveries in the liquid-crystal (LC) technology.

To trace the history of developments of LCD, I interviewed 38 scientists and engineers scattered around US, Japan, and Europe. SECTION I of this paper reviews [1] the developments from the 1964 when the LCD was invented to the 1988 when the 14-in. full-color, full-motion display was demonstrated, which caused to launch the LCD industry.

SECTION II through VI looks at the technical developments done after the LCD industry was launched. In SECTION VII, we look at manufacturing technologies, which enhanced the efficiency of production thus gave rise to the proliferation of the industry. In Section VIII and IX, the paper discusses the business aspects of LCD, showing the LCD industry was born in Japan and has migrated to Korea and Taiwan, and will eventually arrive at China.

II. DEVELOPMENTS FROM 1964 TO 1988

A. Dynamic Sacttering Mode (DSM) of Operation

In 1964 George Heilmeyer discovered DSM and hence invented a liquid-crystal display. When a high electrical-field is applied across two electrically conductive and transparent plates that sandwich negative, nematic liquid-crystals, the LC molecules go into a random motion thus scatter a light incident on the plate making screen appear in a white color..



Figure 1 DSM static-display (courtesy of RCA).

In 1968 RCA held a press conference in New York City on the discovery of the flat electronic display. This caused the display researchers in the world jump in the research of making displays out of liquid crystals..

B. Pocket Calculator

As soon as they heard the news of RCA announcement, Sharp Corp. started the research on liquid crystals. In June 1973, T. Wada et al. developed and marketed a pocket calculator based on the DSM.



Figure 2. Pocket calculator (courtesy of Sharp)

C. Twisted-Nematic (TN) Mode of Operation

Though it was a commercial success, the pocket calculator was the only DSM product that was offered to the market place; DSM was low in contrast and was not able to display color picture thus not applicable to television applications. It required an electrical current, though it was very small, thus was not suitable for use in digital watch, which is expected to have a long working life.

In 1970, Wolfgang Helfrich conceived an idea of solving the above problems. He switched polarized light by relaxing a twisted alignment of positive liquid crystals by applying an electrical field, now called TN (twisted nematic) mode, and Martin Schadt of Hoffmann-La Roche constructed such device (Fig. 3)

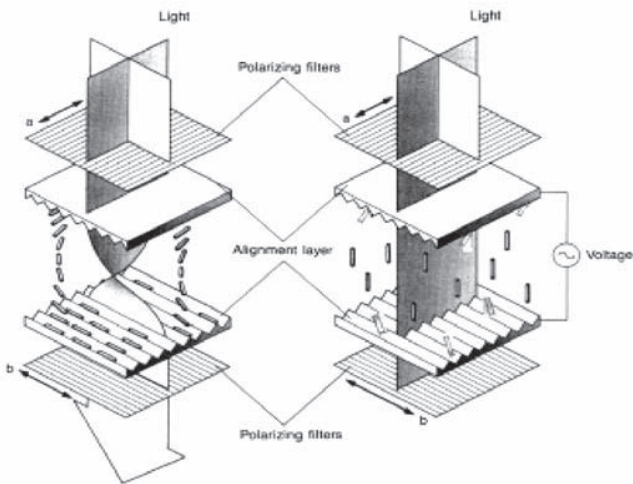

Figure 3 TN mode of operation.

Their February 1971 paper [2] excited the electronic display researchers and made them go into the work on the TN mode. It may not be an overstatement to say that their concept of controlling the amount of light by reorienting liquid crystals with applying electrical field is the basis of the LCD industry today.

D. Digital Watch

In 1971, Optel and Microma marketed DSM watches, but the products stopped working in a short time because of the hydrolysis problem of Schiff's base LCs.. In September 1973, based on the TN mode and using azoxy compounds, Suwa-Seiko marketed the first commercial LCD digital watch.



Figure 4 Digital watch (courtesy of Seiko Epson)

E. Cyanobiphenyl Liquid-Crystals

The LC materials used when the DSM was discovered became the LC state in the temperature range of 117°C to 134°C. The first task at RCA was to find LC materials that work in room temperatures, which turned out to be Schiff's bases, and Sharp used them in the pocket calculator. But the materials were easily hydrolyzed thus had to be tightly sealed for reliability. In 1973, based on the TN mode, a British team made of RRE and Hull University headed by George Gray, synthesized cyanobiphenyl liquid-crystals (Fig.5), which solved shortcomings of Schiff's bases and thus gave LCD the first commercial success.

		Individual temperature range (°C)	Amount (%)
C_5H_{11}		22 → 35	51
C_7H_{15}		28 → 42	25
$C_8H_{17}O$		54 → 80	16
C_5H_{11}		130 → 239	8

Figure 5. Cyanobiphenyl liquid-crystals (courtesy of Cyril Hilsum)

F. TFT (Thin-Film Transistor) Active-Matrix Drive

Engineers tried to use the TN mode for scanning a dot matrix scheme, but they could not achieve more than 60 scanning lines. A Super TN mode was discovered, but was not proper for graphic display. Back in 1968, Bernard Lechner of RCA had conceived the idea of driving the matrix scheme by placing TFTs at each dots..

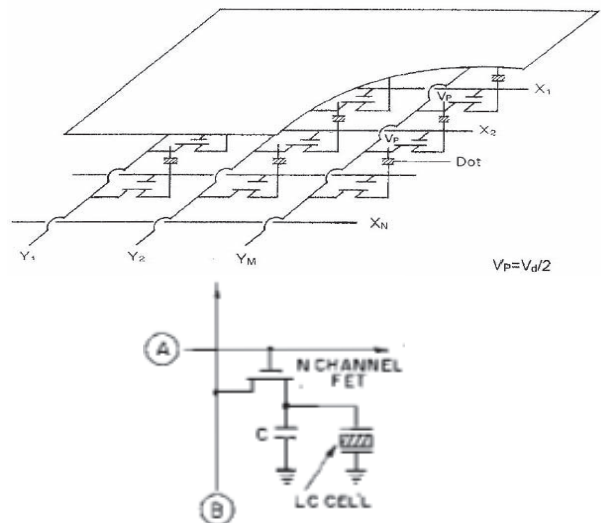

Figure 6. Top: dot-matrix scheme. Bottom: active-matrix drive

In 1973 Peter Brody, Fang Luo et al. of Westinghouse constructed the first dot-matrix display, 6-in. x 6-in., with using CdSe as base TFT material.

G. Fourteen-Inch TV-Type Display

In 1979 the University of Dundee in Scotland invented hydrogen-added amorphous silicon for use in TFT, replacing CdSe. This made it possible to construct LCD TVs. The size of TV started from 2.3-in., then to 3-in. and up to 12.5-in. [3]. In 1988 Washizuka, Take, Yano et al. of Sharp demonstrated a 14-in. full-color, full-motion display, the size of which at minimum could be defined as the size of a table-top television, not of portable type [4].



Figure 6 14-in. TFT AM display (courtesy of Sharp)

This convinced the electronic industry that LCD would soon replace existing cathode ray tube (CRT), and thus caused giant electronic-companies join the burgeoning LCD industry. This 14-in. display vaulted the LCD industry to the major league status.

III. VIEWING ANGLE

Starting from this SECTION on, we look at the developments after the launch of LCD industry..

The first task was to improve the viewing angle of display. With the TN mode, viewed from side of the screen, the display lost contrast or even a gray scale picture was inverted. This was caused by optical birefringence of liquid crystals. Various approaches were tried [5]. Of particular importance, are VA (Vertical Alignment) [6] and its derivatives, MVA (Multidomain Vertical Alignment) [7] and PVA (Patterned Vertical Alignment) [8], and IPS (In-plane Switching).

A. MVA Mode

In the VA mode, with no voltage is applied across the plates, negative LC molecules stand vertically on the plate, and with having cross polarizers, the cell is in a back state. With a voltage is applied, the molecules tilt relative to the original vertical orientation and the cell becomes white or gray.

In 1997, Okamoto et al. of Fujitsu improved the VA by introducing protrusions on the plates to locally control the tilt direction of LC molecules when the voltage is applied (Fig.8). The surfaces of protrusions are faced in different directions, thus creating multidomains (in case of Fig. 8, there are two domains.) In commercial products, a structure having four

domains is commonly used. The structure has made the viewing angle of LCD be equivalent to that of CRT, and has been adopted primarily in the LCDs for use in televisions.

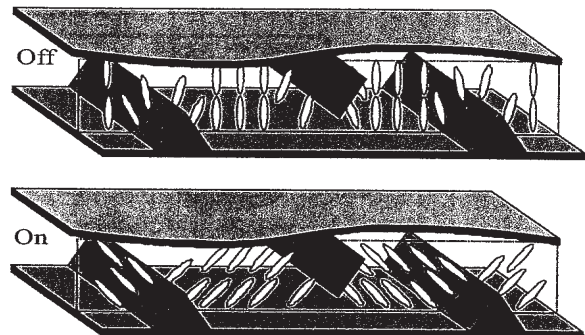

Figure 8 Multidomain Vertical Alignment

B. IPS Mode

In 1992, Gunter Bauer et al. of Fraunhofer Institute in Germany proposed an In-plane Switching, in which LC molecules are rotated horizontally within the plane between the plates [9]. This structure contributed to a wide viewing angle. IPS is the choice of operation by smart phones, in which touching the panel gives a mechanical stress across the plates. The electrical operation of IPS is less affected by being touched because of horizontal orientation of LC molecules.

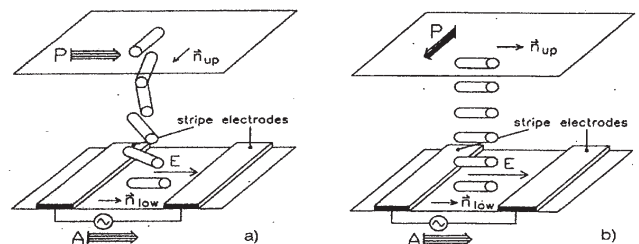

Figure 9 In-plane switching a) OFF state b) ON state

IV. FULL-MOTION VIDEO RESPONSE [10]

LCD used to have a problem of a blur and a trajectory of fast moving object such as a home-run ball observable. Narrowing cell gap was known to improve response time. Improvements have also been made on LC material (viscosity, anisotropy of refractive index, and anisotropy of dielectric constant). In particular, fluorinated LC (SECTION VI) contributed significantly to improve the response time. Another improvement has been to apply an overvoltage when driving LCs, thus causes LC molecules to quickly move into the desired orientation and then return to the normal voltage after an appropriate time, Further improvement was made by interposing a black screen between frames.

V. LED BACKLIGHT

When it was invented, LCD used a fluorescent light as its backlight. In the middle of 2000s, it has started to use light emitting diodes (LEDs). With LED, backlighting can be dynamically controlled thus the dynamic range of picture can be increased; the brightness of backlight is adjusted independently among tiny rectangular regions (Backlight Simulation in Fig.10) corresponding to the local brightness of the exhibited picture.

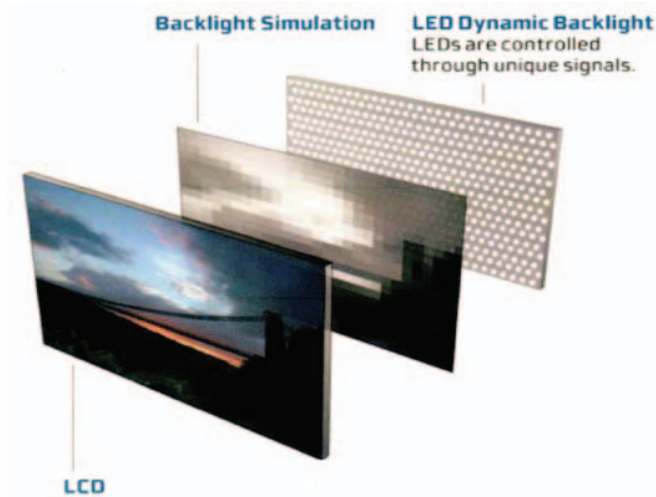

Figure10. Dynamic LED backlighting system

VI FLUORINATED LIQUID CRYSTALS

As new mode of operation was discovered, material suitable for the mode was synthesized, i.e., cyanobiphenyls for TN mode and odd alkenyls for STN mode.

The modes of operation that are used in LCD today are either VA or IPS operated with TFT-AM driving. The materials for use are terminally fluorinated liquid crystals, which have been invented by Merck of Germany [11a] and Chisso in Japan [11b]. They have favorable characteristics such as low viscosity, small refractive-index anisotropy hence large viewing angle, small dielectric anisotropy, and low threshold voltage.

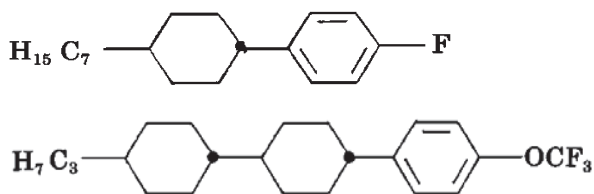

Figure 11. Terminally fluorinated compounds (Merck)

VII. MANUFACTURING TECHNOLOGIES

The LCD industry has been addressing to increase the manufacturing efficiency thereby to reduce panel costs.

A.. Mother Glass

For mass production, LCD industry uses a mother glass, on which multiple LCDs are fabricated. The size of the mother glass has ever become larger. In 2004, Sharp started manufacturing panels with using the 6th-Generation glass, the size of which is 1.8 M x 1.5 M. This was followed by Samsung in 2005 with the 7th-Generation glass (2.2 M x 1.87 M). In 2009, Sharp used the 10th-Generation glass, the size of which is as large as 3.05 M x 2.85 M.



Figure12 6th-Generation glass can have six 32-in. LCD substrates.

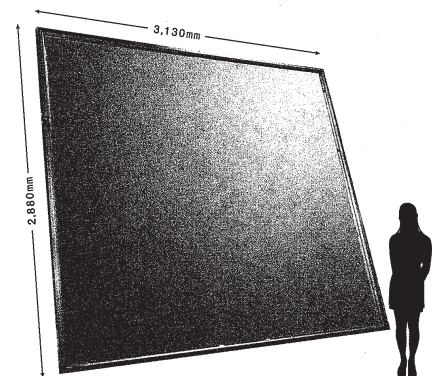

Figure13. Top: 4th-G and 6th-G mother glass. Bottom: 10th-G mother glass; a man on the side can no longer hold it. (Sharp)

B. CVD (Chemical Vapor Deposition) System

As the size of mother glass has been enlarged, production equipment has become gigantic. Fig. 14 shows a chemical vapor deposition (CVD) system used for a 8.5th-G mother glass [12].



Figure14. 8.5th-Generation CVD system (courtesy of AKT)

C. Plant Complex

For the efficiency of supply-chain, LCD factory now has in its premise a glass factory and color filter factories operated by supporting companies. Those components are carried on conveyor belts buried in the ground.

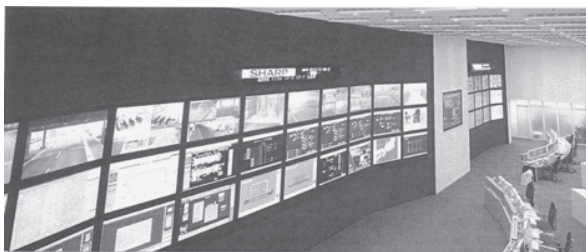
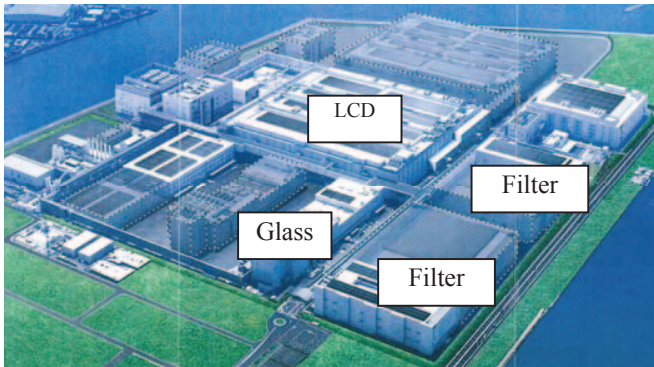

Figure 15. Top: 10th-G LCD factory complex in Sakai, Osaka Bottom: The control room. (courtesy of Sharp)

The supply of components and chemicals are monitored and controlled by operators in the control room, which looks like the Mission Control Center in Houston.

VIII. LCD INDUSTRY

Now we look at the business side of LCD. In dollar wise, the LCD industry took over CRT industry in 2001 (Table 1), and in the-number-of-unit wise in 2005 (Fig 16).

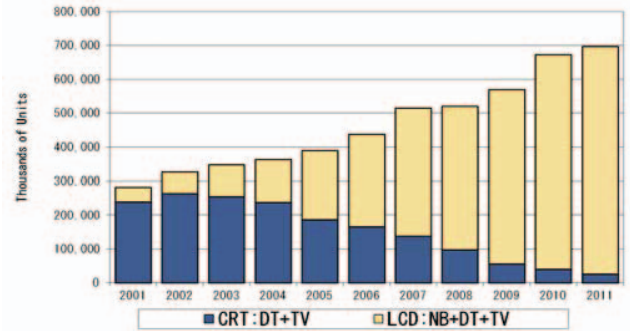

Figure 16 Cross over from CRT to LCD (IHS iSuppli)

Among various technologies, LCD now dominates the electronic display market (Table 1). The share of Organic LED (OLED) Display is 1.3%, and it remains to be seen if it grows as some expect.

	2,000	2,002	2,004	2,006	2,008	2,010
AM LCD	16,797	18,201	58,872	71,184	95,249	109,445
PM LCD	5,570	5,137	6,893	5,108	3,184	
all LCD	22,367	23,338	65,765	76,292	98,433	109,445
CRT	23,400	20,086	18,907	16,435	4,518	1,870
PDP		2,203	5,490	7,688	6,793	7,800
OLED		92	410	550	610	1,467
Others		1,306	1,402	1,457	1,441	1,460

Table 1. Electronics Displays. in unit of 1,000 dollars (IHS iSuppli)

The use of LCDs started from Note PC and Desk Top Monitor in 1990s, and then moved to TV in late 2000s (Fig. 17).

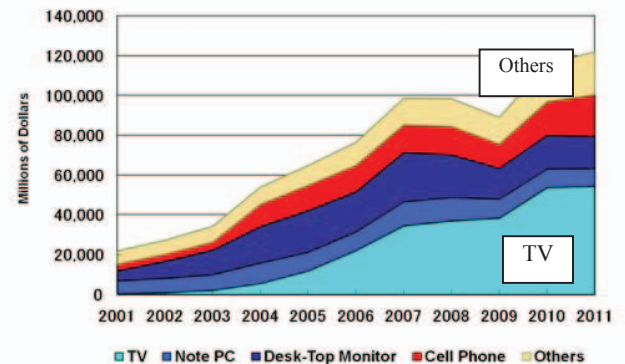

Figure 17 Use of LCDs (IHS iSuppli)

IX. MIGRATION OF INDUSTRY

As we look back the history, technology and its industry have migrated from upstream to downstream as time has progressed. Color CRT-TV industry was founded in 1960s by RCA, and in 1980s was taken over by Japanese. DRAM industry was founded in 1970s by Intel, and was taken over by Japanese in 1980s. It is now owned by Koreans. Likewise, LCD industry was founded in early 1990 by Sharp of Japan, and already in late 1990 started to migrate to Korea [13] and Taiwan [14]. As time has come down, the migration has accelerated; Color CRT-TV took 15 years to move from US to Japan, DRAM 10 years from US to Japan, and a 6th-G LCD factory only 6 years from Kameyama, Japan to Nanjing, China.

| 1960 | 1970 | 1980 | 1990 | 2000 | 2010

CRT TV: US→(15yrs)→Japan → China

DRAM : US→(10)→Japan→Korea

LCD : Japan(6)Korea.Taiwan.China

Table 2 Migration of electronics industries

In the first half of 1990s Japan had almost 100% share of LCD production, whereas, in 2011 it has 6%, instead, Korea and Taiwan together own 94 %. (Fig.18).

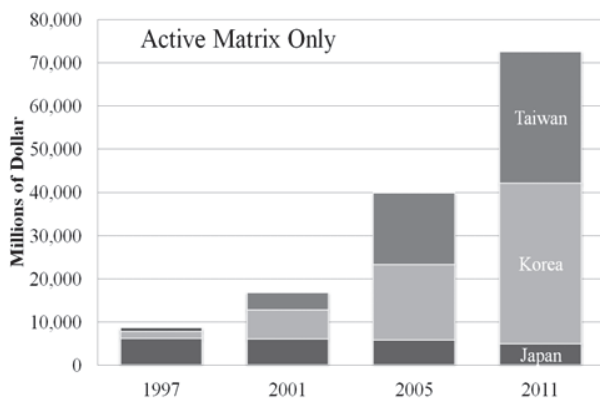

Figure 18. Countries that supply large LCDs (IHS iSuppli)

X. CONCLUSIONS

Looking back the history of LCD, the US opened the door for a flat electronics display with inventing DSM, Europe invented basic mode of operation, TN, VA, and IPS; and synthesized basic materials, cyanobiphenyls and terminally fluorinated compounds. Japan perfected the inventions by fabricating the 14-in. TV display and thus founded the LCD industry. Korea and Taiwan have taken over the industry by increasing manufacturing efficiency. China, which has already been the base for the assembly of LCD-TVs, is expected soon to take over the manufacturing of LCD-panels..

The number of LCDs in consumer's and businessman's use is considered to be over 9.4 Billion units world-wide (accumulating the shipments of TFT-AM LCDs for phones, monitors, PCs, and TVs from 2009 to 2011; IHS iSuppli). The number is greater than the world population of 7 Billion. The invention of LCD is not only one of the greatest technical achievements in the 20th century, it has greatly enriched our life and enhanced business activities.

ACKNOWLEDGEMENT

The author wishes to thank M. Ishii, J. Masuda, H. Kitahara, and H. Yoshida for giving suggestions and supplying data for writing this article.

REFERENCE

- [1] H. Kawamoto, "The History of Liquid-Crystal Displays," *IEEE Proc.* vol. 90, no. 4, pp. 469-500, April 2002
- [2] M. Schadt and W. Helfrich, "Voltage-dependent optical activity of a twisted nematic liquid crystal," *Appl. Phys. Lett.*, vol. 18, no. 4, pp. 127-128, Feb. 1971.
- [3] M. Takeda, S. Ogo, T. Tamura, H. Kamiura, H. Noda, T. Kawaguchi, I. Yamashita, D. Ando, and H. Kuroda, "12.5" LCD Addressed by a-Si TFTs Employing Redundancy Technology," *Japan Display 1986*, p. 204
- [4] T. Nagayasu, T. Oketani, T. Hirobe, H. Kato, S. Mizushima, H. Take, K. Yano, M. Hijikigawa, and I. Washizuka, "A 14-in-diagonal full-color a-Si TFT LCD," in *Proc. Int. Display Research Conf.*, San Diego, Oct. 1988, pp. 56-58
- [5] M. Koden, "Wide Viewing Angle Technologies of TFT-LCDs," *Sharp Technical Journal*, vol. 74, Aug 1999, pp. 55-60
- [6] M. F. Schiekol and K. Fahrenschon, "Deformation of Nematic Liquid Crystals with Vertical Orientation in Electrical Field," *Appl. Phys. Letters*, vol. 19, p. 391, 1971
- [7] Y. Koike, S. Kataoka, T. Sasaki, H. Chida, H. Tsuda, A. Takeda, K. Ohmuro, T. Sasabayashi, and K. Okamoto, "A vertically aligned LCD providing super-high image quality," in *IDW '97*, 1997, p. 159.
- [8] K. H. Kim, K. Lee, S. B. Park, J. K. Song, S. Kim, and J. H. Souk, "Domain divided vertical alignment mode with optimized fringe field effect," *Proc. Asia Display '98*, 1998, p.383
- [9] R. Kiefer, B. Weber, F. Windscheid, and G. Bauer, "Plane switching of nematic liquid crystals," *Proc. Japan Display '92*, 1992, p.547
- [10] Y. Ishii, "The World of Liquid-Crystal Display TVs," *IEEE J. of Display Tech*, vol. 3, no. 4, pp. 351-360, Dec. 2007
- [11a] H. J. Plach, G. Weber, and B. Rieger, "Liquid crystal mixtures for active matrix displays using new terminally fluorinated compounds," *Proc. SID*, Las Vegas, May 1990, pp. 91-94
- [11b] Y. Goto and T. Ogawa, "Cyclohexane Derivative and Liquid Crystal Composition Containing the Same," *US Patent* 4,820,443, Applied: Feb 1, 1988, Patented: Apr. 11, 1989
- [12] Y. T. Yang, T. K. Woo, S. Y. Choi, T. Takehara, Y. Nishimura, and J. White, "The Latest Plasma-Enhanced Chemical-Vapor Deposition Technology for Large-Size Processing," *IEEE J. of Display Tech*, vol. 3, no. 4, pp. 386-391, Dec. 2007
- [13] J. Jang, S. Lim, and M. Oh, "Technological Developments and Production of Falt Panel Display in Korea," *IEEE Proc.* vol. 90, no. 4, pp. 501-513, April 2002
- [14] Fan Luo, "The World Is Flat-The Taiwan Experiences" *ASID 2006*, October 2006, New Delhi, india