

INTRODUCTION TO "THE HISTORY OF OFDM"

OFDM, orthogonal frequency-division multiplexing, plays a significant role in modern telecommunications, ranging from its use in DSL-modem technology to 802.11 Wi-Fi wireless systems. Work underway in next-generation mobile wireless systems exploits the advantages of using OFDM techniques as well. OFDM combined with MIMO technology is expected to provide immense improvements in wireless transmission capacity. We are pleased to have for this month's History Column a succinct, yet

authoritative, history of this technology. Its author, Steve Weinstein, a leader in the Communications Society and one of its past Presidents, was one of the pioneers in the development of OFDM technology. He thus writes from personal experience in describing the history of OFDM. We commend the article following to all readers of IEEE Communications Magazine.

—Mischa Schwartz

THE HISTORY OF ORTHOGONAL FREQUENCY-DIVISION MULTIPLEXING

STEPHEN B. WEINSTEIN

Orthogonal frequency-division multiplexing (OFDM) is one of those ideas that had been building for a very long time, and became a practical reality when the appearance of mass market applications coincided with the availability of efficient software and electronic technologies. This article describes the background and some of the striking early development of OFDM, with explanation of the motivations for using it. I presume a broad definition of OFDM as frequency-division multiplexing (FDM) in which sub-channels overlap without interfering. It does not necessarily require the discrete Fourier transform (DFT) or its fast Fourier transform (FFT) computational method.

THE FDM BACKGROUND

There is a long history behind FDM. Stimulated by telegraph companies hoping to multiply their profits, entrepreneurs and inventors of the 1870s sought ways to multiply the capacity of a telegraph transmission line by carrying several noninterfering information channels. Time-division multi-

plexing (TDM) or more dynamic time-division multiple access (TDMA), with users taking turns in using time slots, was invented by Baudot [1] and others, and was particularly useful when the telegraph line was underutilized, with significant gaps between characters. Of course, burst speed would be limited by intersymbol interference — the dispersion of a pulse into its neighbors — for which there was not yet a good channel equalizer. There were many initiatives with alternative multiplexing schemes. Edison's "quadruplex" telegraphy system [edison.rutgers.edu/quad.htm], for example, sent two messages simultaneously (in each direction), one varying amplitude and the other polarity.

Interest turned fairly early to frequency-division multiplexing. The evolution to the techniques known as multitone or OFDM began in the innovations of the 1870s. Alexander Graham Bell was initially funded by his future father-in-law Gardiner Hubbard to work on "harmonic telegraphy," which was FDM transmission of multiple telegraph channels [2], with the equipment shown in Fig. 1. His competitor Elisha Gray simultaneously

worked in this area and had an earlier patent [3]. Thomas Edison was also in hot pursuit of the multitone telegraph [4]. The access facilities for these techniques might be considered early implementations of digital subscriber line (DSL). However, Bell's first love was telephony, and he focused his energy on analog voice transmission rather than discrete-tone multiplexed telegraphy.

FDM came into its largest general use in carrier systems for analog telephony. As described by Schwartz [5], FDM for analog voice signals may first have been demonstrated by George Squier, a major in the U.S. Army Signal Corps, in 1910, in an apparatus with one baseband and one passband channel. AT&T was skeptical, claiming too much dispersion and loss at the higher frequencies it assumed were required. But AT&T deployed its own five-channel system in 1918 that used not-so-high subcarrier frequencies and repeaters. FDM became the main multiplexing mechanism for telephone carrier systems. Bandwidth and dispersion were not serious problems with the relatively modest spacing of repeaters,



Figure 1. Bell's harmonic telegraph, using reeds responsive to different frequencies. Photos of replicas of the original equipment used with permission of Telecommunications Museum, LaSalle, Quebec, Canada.

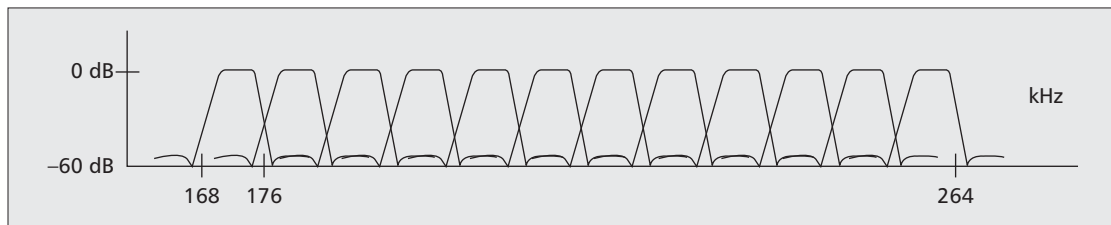

Figure 2. N2 carrier system frequency spectrum for 12 telephone subchannels, derived from [6].

and 8 kHz subchannel spacing was provided for 4 kHz voice signals. The N2 carrier system of the mid-1960s (Fig. 2) used double sideband amplitude modulation and transmitted up to 200 miles [6].

With the introduction of digital telephony, FDM carrier systems with individual subchannels for voice signals began, in the 1970s, to be replaced by TDM/FDM and pure TDM systems. Of course, the higher the aggregate speed of a TDM transmission line, the wider the bandwidth of this single channel and the greater the potential for intersymbol interference. High-frequency (HF) radio systems had a particularly severe transmission problem, with selective fading (Fig. 3) across the transmission bandwidth causing considerable pulse dispersion and intersymbol interference.

The answer to this problem with serial data transmission in radio frequency (RF) channels (and later in DSL with severely distorted channels) was to go back to fine-grained FDM, concentrating data in the less faded subchannels. Each subchannel would be affected by only a small part of the channel characteristic (Fig. 4), which could be approximated by constant amplitude and phase. This narrow subchannel could easily be equalized, in a complex analytic model, by multiplication by the inverse complex number. The hope that the saving in equalization effort would compensate for the greater complexity of FDM became a reality with OFDM.

DENSE SUBCHANNELS

But FDM, too, had drawbacks:

- The waste of scarce wireless frequency spectrum in guard spaces between the subchannels
- The large complexity of a multiplicity of separate modulators for the different subchannels

The first problem was alleviated by the concept of OFDM as an FDM system with subchannel signals having overlapping but *non-interfering* frequen-

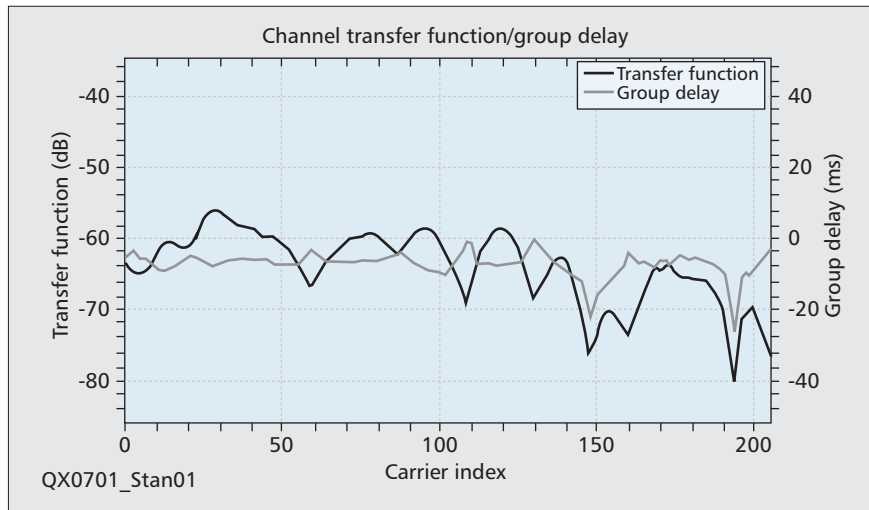

Figure 3. Selective fading in an HF radio channel. Source: J. Stanley, "Observing Selective Fading in Real Time with Dream Software," *QEX*, Jan-Feb 2007, www.arrl.org/qex/2007/01/stanley.pdf.

cy spectra. Harmonic sinusoids were an obvious choice, since they are orthogonal on a period T of the fundamental (lowest) subcarrier signal. In an OFDM system sending complex data $\{a_n\}$, the subchannel signals,

$$\begin{aligned} sn(t) &= a_n g(t) \exp(j2\pi f_n t), \\ f_n &= n/T, \quad 0 \leq n \leq N-1, \\ g(t) &= 1 \text{ on the interval} \\ &\quad 0 < t < T \text{ and zero elsewhere,} \end{aligned} \quad (1)$$

are mutually orthogonal despite overlapping spectra. N , the number of subchannels, is arbitrary and varies among applications. The rectangular pulse shape $g(t)$ has a $\text{sinc}(f)/f$ spectrum making a subchannel spectrum heavily overlap its neighbors, as shown in Fig. 5. An OFDM signal block, on the interval T , can be defined as the sum of these subchannel signals, and, ideally, one block immediately follows another. In the absence of channel distortion, there is neither inter-subchannel nor intersymbol interference.

It is easy to show [7] that an N -point inverse DFT (IDFT) operating on the (possibly complex) data block $\{a_0, a_1, \dots, a_{N-1}\}$,

$$s_k = \sum_{n=0}^{N-1} a_n \exp\{j2\pi nk/N\}, \quad (2)$$

generates samples, at time intervals T/N , of the OFDM signal that is the sum of the subchannel signals defined in Eq. 1. Operating on the received signal with the DFT, like Eq. 2 but with a negative exponent, recovers the data. Figure 6 is a simplified illustration of the entire OFDM system, including the cyclic prefix operation described later.

With rectangular $g(t)$ and a distorted channel comes intersymbol interference, a problem addressed earlier, but there is the advantage that the transmitter does not have to know the channel characteristic (although the receiver does, for equalization purposes). However, if the channel characteristic is known at the transmitter, many other pulse shapes are possible. Chang [8], in a fundamental contribution to OFDM, developed general conditions for the shapes of pulses, defined as the combination of transmitter filter and channel characteristic, with bandlimited but still overlapping spectra. Such pulses, including the

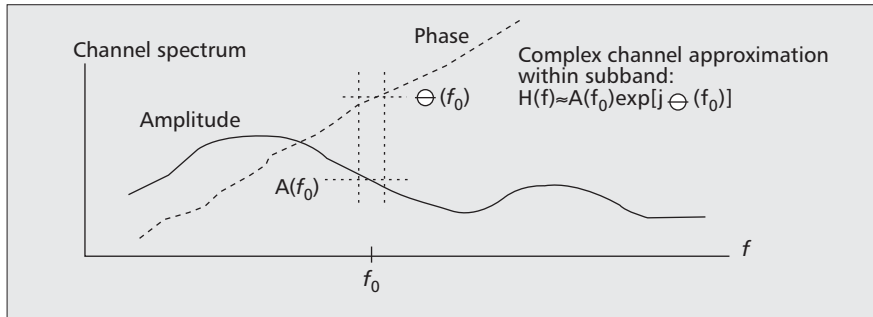

Figure 4. Approximation of a distorted channel, within a subband, by constant amplitude and phase.

transmitter of the channel; the transmit and receive filters, in tandem, have a Nyquist characteristic. Saltzberg investigated the performance of Chang's model in a dispersive channel, assuming both intersymbol and inter-subchannel interference as well as phase offset, and tested alternative pulse characteristics meeting the Chang criteria. He generated performance criteria in terms of the classical eye opening derived from superposed outputs with different data input sequences. Chang and Gibby followed up with analysis of the performance of Saltzberg's system in the presence of sampling time error, carrier phase offset, and phase distortions in its filters [10].

Hirosaki [11] contributed further enhancements to OFDM/OQAM, particularly much faster processing through replacement of an N -point DFT with an $N/2$ -point DFT, if the passband carrier frequency is chosen such that the fractional part of f_1/Δ_f is 0.5, where f_1 is the lowest subcarrier and Δ_f is the subchannel spacing. For digital signal processor (DSP) implementation, he determined that his OFDM/OQAM design has a

full cosine-rolloff pulse of Fig. 5, make a viable OFDM system "without inter-channel and intersymbol interferences."

Figure 7 illustrates the Chang system with transmitting filters A_1, \dots, A_n depending on the magnitude of the channel transfer function $H(f)$. If the channel characteristic is effectively flat across a narrow subchannel, it may be possible to effectively ignore the dependence on $H(f)$. Chang assumed real data for the amplitude modulation in each subchannel.

Saltzberg [9] extended Chang's work to complex data (e.g., quadrature amplitude modulation [QAM]). The system he described (Fig. 7) is now called OFDM-OQAM (offset QAM). In order to eliminate intersymbol and inter-subband interference (for a distortionless transmission channel), he showed that the timing of the in-phase and quadrature data streams should be staggered by $T/2$ and adjacent subbands staggered the other way, as Fig. 8 indicates. He did not presume knowledge at the

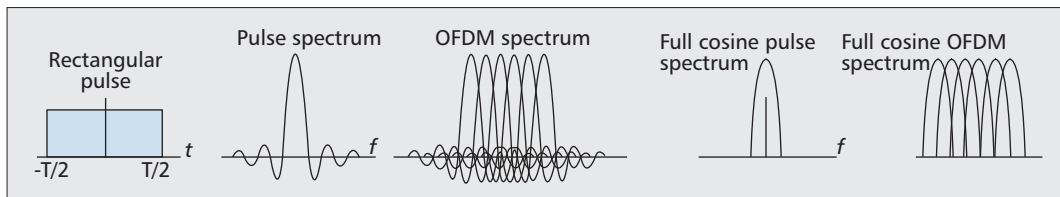

Figure 5. Rectangular and full-cosine-rolloff pulses and resulting OFDM spectra.

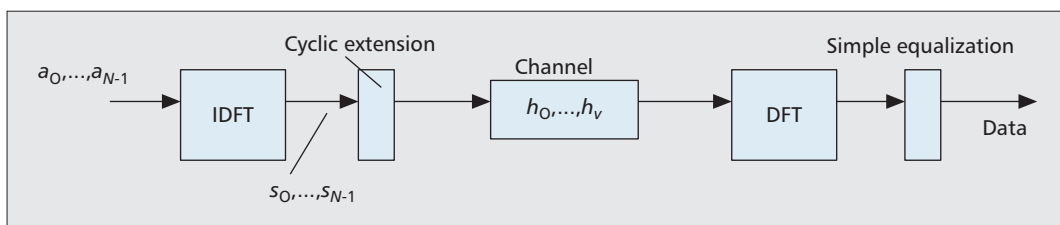

Figure 6. OFDM system.

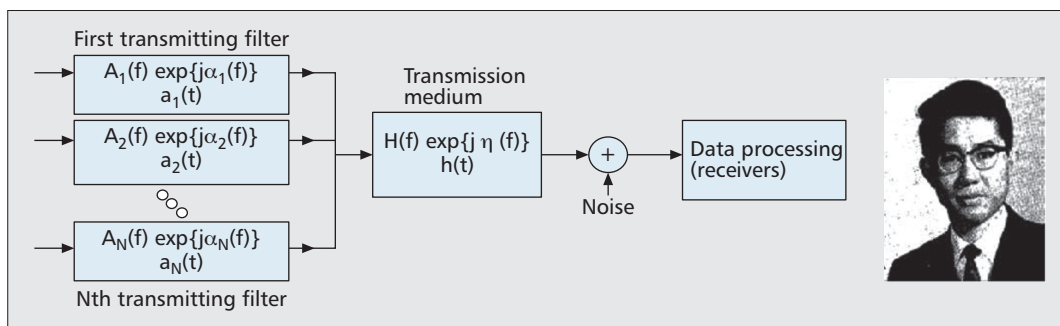

Figure 7. Chang system for OFDM with channel-dependent transmitter filters [8].

significant advantage over single-channel data transmission.

Other researchers continued to improve OFDM/OQAM. A particular interest has been the design of pulses that are well localized (limited) in both time and frequency. The work of Bolcskei, Duhamel and Hleiss [12], yielding symmetric pulses that are well localized and realize performance close to the optimum OFDM spectral efficiency, is a good example (Fig. 9).

SIGNAL GENERATION USING THE DFT AND ITS FFT IMPLEMENTATION

The second problem of FDM, efficiently generating a multichannel, closely packed (OFDM) data signal, was solved by the FFT implementation of the DFT. Zimmerman and Kirsch published a remarkable paper on the design of an HF (high frequency) radio OFDM transceiver (KATHRYN) in 1967 [13], following a 1965 article by Bello that described the system's response to channel impairments including use of a time guard interval.

KATHRYN generated the orthogonal subchannel signals using the DFT in an analog hardware implementation. There were 34 subchannels in a 3 KHz bandwidth, as shown in Fig. 10 together with the equipment. The system appears to have distributed power uniformly over all subchannels, except for varying the transmission rate by using subchannels according to conditions. There was binary in-phase and quadrature modulation of each subcarrier, although

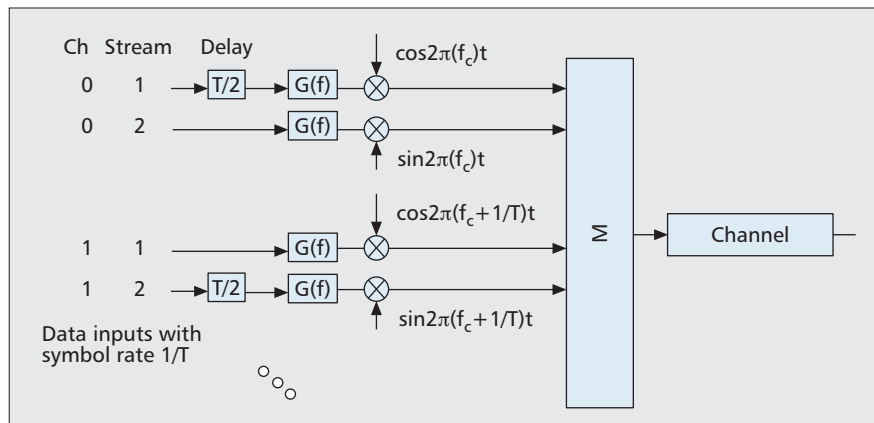

Figure 8. OFDM-OQAM implementation with staggered time-delayed subchannels (adapted from Saltzberg [9] and Hirosaki [11]). Only two transmitter subchannels are shown, with the pattern repeating for additional subchannel pairs and with a comparable structure in the receiver.

apparently not with the OFDM-OQAM insights of later years, but there was the understanding that larger signal constellations could be used in the subchannels with better channel characteristics.

The transition to the FFT for generating the DFT was soon to follow. Paul Ebert, Jack Salz, and I were motivated in the late 1960s to find a good application in data communication for the recently announced Cooley-Tukey fast Fourier transform (FFT) algorithm [14], a reduced-complexity way to compute the discrete Fourier transform requiring approximately $M \log N$ operations rather than N^2 . It was later discovered that the FFT may go back to the great mathematician Karl Friedrich Gauss (around 1805) who used it to help calculate elements of a finite Fourier series for the computation of

asteroid orbits [15]. The FFT, exploiting the periodicity and symmetry properties of exponentials, factors a length N DFT into a number of shorter-length DFTs with multiple re-use of the results of these shorter-length DFTs [cnx.org/content/m12026/latest/].

It became apparent to us that, since the DFT could generate a data signal in parallel subbands, greatly reducing equalization complexity at the cost of the complexity of generating the subband signals, the use of the FFT might swing the advantage to OFDM over single-carrier systems. OFDM would also, as Zimmerman and Kirsch noted in 1967, support flexible utilization of a spectrum that was subject to fading or (as in ADSL) frequency-selective interference. We published our concept [7] (Fig. 11) but there was little interest in

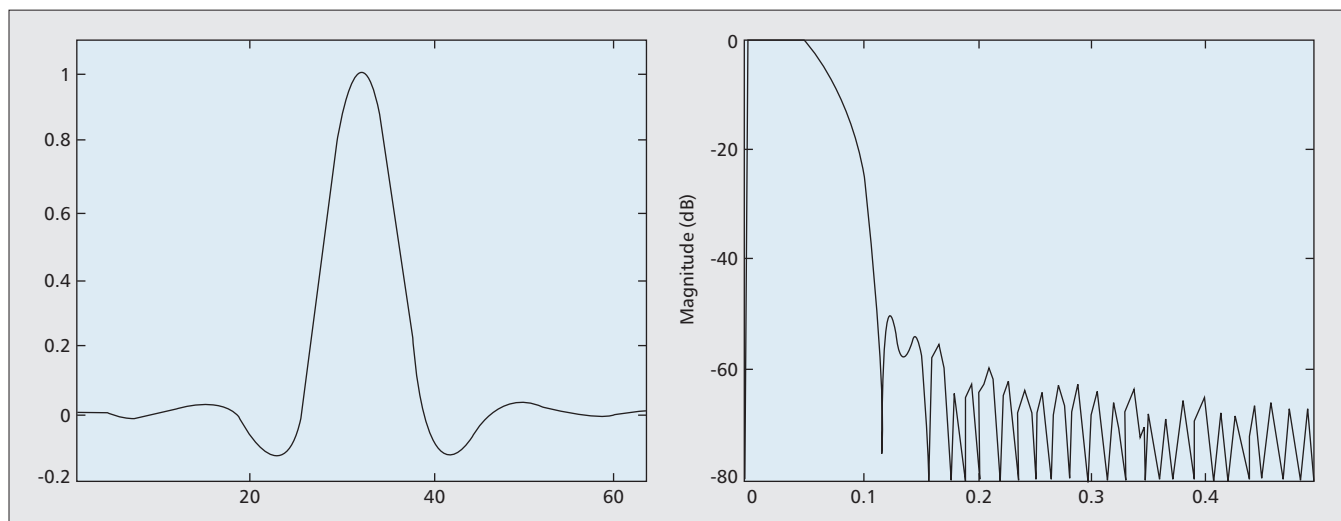

Figure 9. OFDM/OQAM pulse shaping filter time and frequency characteristics, for a pulse well localized in both time and frequency [12].

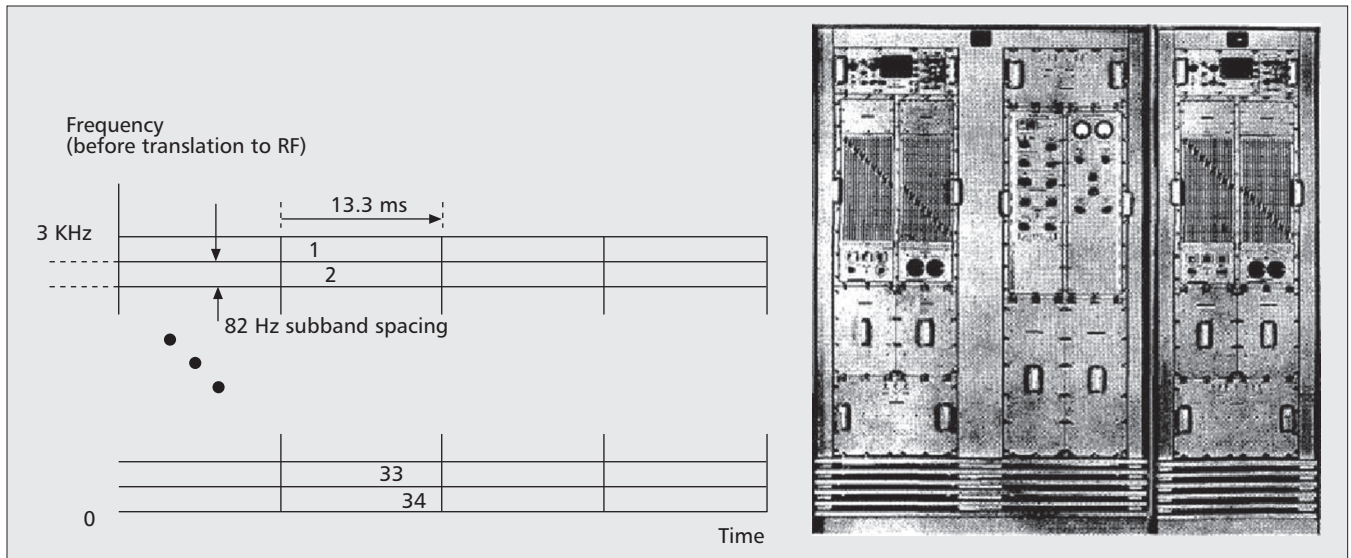

Figure 10. The 1967 KATHRYN high-frequency radio OFDM system [13].

this approach within our voiceband data communication division at Bell Laboratories. It did not even seem worthwhile applying for a patent. The big application areas of ADSL, wireless communications, and digital audio and video broadcasting (DAB-DVB) were yet to come.

Using the FFT made OFDM viable, but the debate over the relative complexity of OFDM signal processing and single carrier wide-channel equalization continues to this day. Sari [16] and others [17, 18] noted that generating and detecting an OFDM signal is similar to equalizing a single carrier system in the frequency domain. The flexibility of OFDM appears to have made it the winner in current practice.

ADSL: THE FIRST MAJOR OFDM APPLICATION

Although, as exemplified by the KATHRYN system of the mid-1960s, wireless applications apparently preceded wired ones, the first major consumer-oriented application was in ADSL (asymmetric digital subscriber line). DSL had been investigated at Bell Labs where Gitlin and others defined single-channel systems that could work at megabit rate on subscriber lines as long as 18 kilofeet [19], and studies were made in the late 1980s of alternative implementations using OFDM and CAP (carrierless amplitude-phase modulation, a variation on single-carrier QAM). Performance seemed comparable and Bell Labs subsequently developed CAP modems building on its long experience

with voiceband modems. ADSL, with a much higher transmission rate toward the subscriber, was defined by Lechleider and his colleagues at Bellcore around the same time. Much subsequent development of ADSL and higher speed DSL systems was pursued at Bell Labs by Lawrence and his colleagues [20]. It was left to Cioffi and his company, Amati, to develop discrete multitone (DMT, essentially OFDM) [21].

Amati's prototype DMT ADSL modem won a competition with CAP in a Bellcore-sponsored test in January, 1993. There were a number of reasons for the success of multitone, but the main one, as suggested to me by John Cioffi, may have been its capability to avoid expending power in parts of the spectrum characterized by very large noise or a deep channel null, a capability difficult to achieve for single-carrier systems. The Shannon capacity-achieving water-pouring analysis, illustrated in Fig. 13 where power (water) is poured onto the curve representing the ratio of noise power to channel magnitude squared, can result in islands where no power at all should be placed. The Amati group devised dynamic bit assignment strategies that assigned data (and signal power) in accordance with the fluctuating channel and noise conditions typical of a twisted pair subscriber line. A second Bellcore-sponsored competition for very high speed DSL (VDSL), held in 2003, also showed better performance for DMT.

The original and still prevalent ADSL1 technology [22] uses a 256-point DFT with subcarriers separated by 4.3125 kHz and a (block) symbol rate of 4000/s. Including a guard period of

40 samples, the sampling rate of the transmitted signal is 2.208 million/s. The data rate is any multiple of 32 kb/s up to approximately 8 Mb/s. Subbands 0–32 (except for a few lowest subbands consumed by analog telephone service and a guard band) are used for upstream transmission and subbands 33–255 for downstream. The total subscriber line bandwidth, upstream and downstream, is about 1.1 MHz.

For the later ADSL2+ on shorter subscriber lines, 512 subbands are used, and the sampling rate is 4.416 million/s, realizing a maximum data rate of about 24 Mb/s. The still newer VDSL, in hybrid systems with the shortest subscriber lines, can use the same subcarrier spacing and symbol rate as does ADSL but up to 4096 subbands, consuming about 17.6 MHz of bandwidth. Alternatively, VDSL can use an 8 kHz symbol rate and 8.625 kHz subcarrier spacing, supporting up to 150 Mb/s downstream data rate and 75 Mb/s upstream. Upstream and downstream groups of subbands are distributed over the total bandwidth.

Despite early development of ADSL1 in the United States, the first DMT ADSL deployments, using Amati equipment, were in other countries, beginning with British Telecom in late 1993 and early 1994, offering 2.024 Mb/s downstream. France Telecom deployed an 8 Mb/s system (on relatively short subscriber lines) in 1994, Deutsche Telekom deployed 2 Mb/s and 8 Mb/s systems in 1994, Telecom Italia offered 4 Mb/s and 8 Mb/s ADSL in 1994/1995, and Telstra initiated a 6 Mb/s system (including live video) in

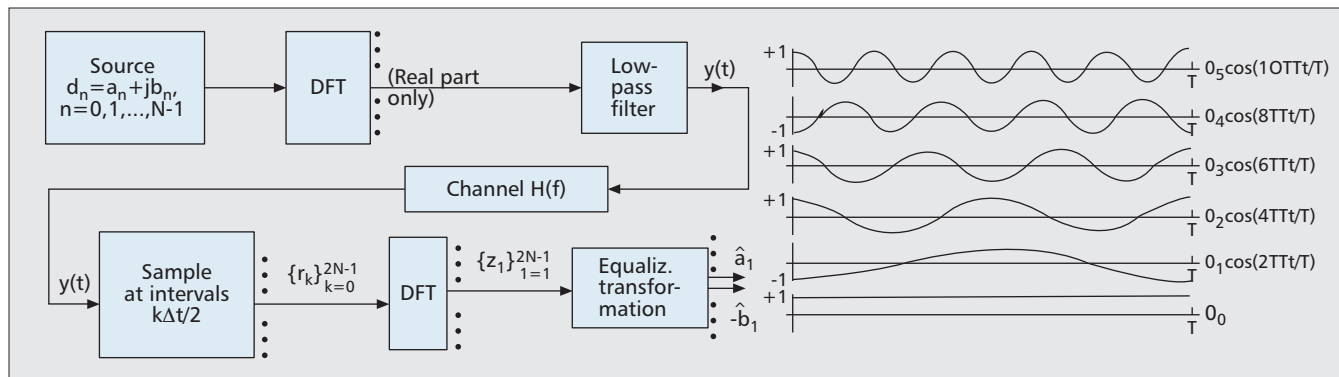

Figure 11. Original figures from 1971 Weinstein-Ebert paper [7]. Left: system including simple (one complex multiplication) equalization; Right: multiple subchannel tones.

Australia in 1994/1995. Finally, in 1997, a group of Bell operating companies in the United States decided to go with DMT ADSL. Texas Instruments purchased Amati in late 1997 for \$450 million, the first big economic success for an OFDM equipment manufacturer.

MEETING OFDM CHALLENGES: THE CYCLIC PREFIX AND OVERCOMING HIGH PEAK TO AVERAGE RATIO

Pulse localization such as that used in OFDM-OQAM can minimize intersymbol interference, but for ordinary OFDM with a rectangular pulse a dispersive channel causes intersymbol interference. It can be mitigated by a time-domain guard interval between OFDM symbols (blocks), or by a cyclic prefix to the OFDM block. The proportional overhead cost is minimized by use of long OFDM symbols (large N).

A guard interval equal to the “memory” (dispersion time) v of the channel, during which no energy is transmitted, is the simplest solution. However, the channel is used more efficiently if something is transmitted during the guard space that contributes to the signal energy without introducing intersymbol interference.¹ This is the *cyclic prefix*, the repetition of the last part of the transmitted signal during the prefix interval, as suggested in Fig. 14. Assum-

ing the channel is known at the receiver, the OFDM data block may be very simply detected as described below.

The cyclic prefix was, to the author’s knowledge, first proposed by Peled and Ruiz [23] in 1980. The involvement of a circulant matrix has long been recognized, but Jack Salz² recently developed a particularly elegant circulant matrix explanation for why the input data-IDFT-cyclic prefix-channel-DFT series of operations decouples the subchannels and makes detection easy, without the transmitter needing any knowledge of the channel.

Assume transmitted signal samples $(s_{N-v}, \dots, s_{N-1}, s_0, s_1, \dots, s_{N-1})$, where the first v elements are the cyclic prefix repeating the last v samples of the OFDM signal samples generated by the IDFT operating on the input data (a_0, \dots, a_{N-1}) . The samples of the channel impulse response are (h_0, \dots, h_v) . Convolution of the transmitted signal vector with the channel (Fig. 6) yields the sampled received signal $(r_{-v}, \dots, r_{-1}, r_0, r_1, \dots, r_{N-1}, r_N, \dots, r_{N+v})$, of which only r_0 through r_{N-1} are applied to the DFT processor. If the channel has, for exam-

ple, memory $v = 2$, a little mathematics shows that these operations can be expressed as

$$\begin{pmatrix} \text{DFT} \end{pmatrix} \begin{pmatrix} h_0 & 0 & h_2 & h_1 \\ h_1 & h_0 & 0 & h_2 \\ h_2 & h_1 & h_0 & 0 \\ 0 & h_2 & h_1 & h_0 \end{pmatrix} \begin{pmatrix} \text{IDFT} \end{pmatrix} \begin{pmatrix} \bar{a} \\ \bar{a} \end{pmatrix} = \begin{pmatrix} H_0 & & 0 \\ & H_1 & \\ & & H_2 \\ 0 & & & H_3 \end{pmatrix} \begin{pmatrix} \bar{a} \\ \bar{a} \end{pmatrix} \quad (3)$$

where the elements at the upper right of the equivalent channel matrix HC (between the DFT and the IDFT) represent the effect of the cyclic prefix. This matrix is a circulant matrix in which each row is a cyclic shift of the row above it. (H_0, \dots, H_3) are frequency-domain samples of the channel transfer function.

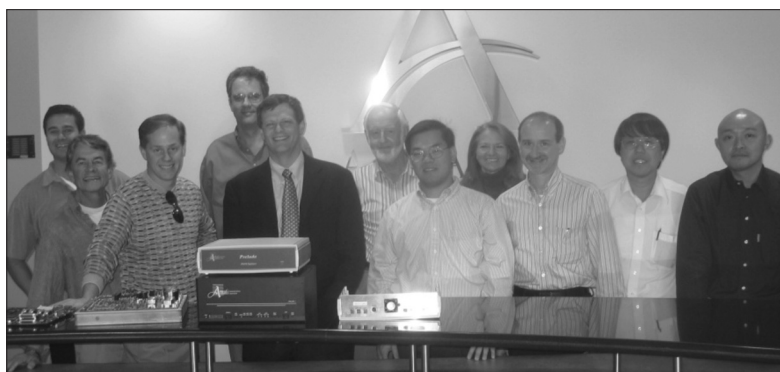

Figure 12. John Cioffi (center, dark suit) and his Amati colleagues reassembled in 2005 for this photograph with their experimental multitone modem of 1993 (plastic box on top) and its early commercial successor. [Photo courtesy John Cioffi.]

¹ A null prefix can be used at the transmitter, with the cyclic prefix inserted in the receiver, at some performance cost.

² Unpublished, referenced here by permission of Jack Salz.

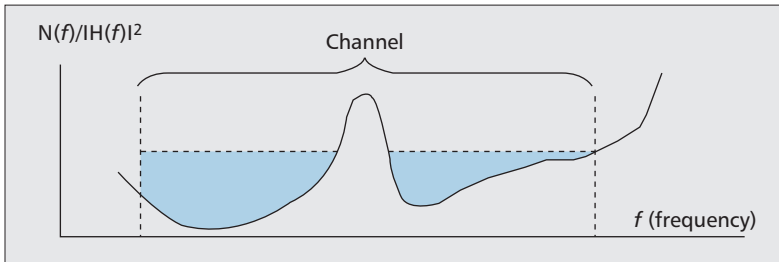

Figure 13. “Water pouring,” showing the optimum allocation of transmitted power that realizes channel capacity. For simplicity, only the positive-frequency spectrum is shown.

outright jamming. It was notably implemented in the Bluetooth standard (IEEE 802.15.1). More recently, it appeared in the context of cellular mobile communications in the Flarion Flash OFDM system [28], now a product of Qualcomm, which uses fast hopping among the OFDM subbands to provide flexibility to accommodate different classes of IP (Internet Protocol) traffic, and to minimize interference between mobile units on either side of a cell boundary.

With resistance to fast selective fading in mind, Cimini [29] explored application of OFDM to the difficult environment of cellular mobile systems. The KATHRYN and other early systems presumed slow fading, unlike that experienced in a vehicle moving at 60 mi/h. Coupling OFDM with corrections using pilot tones, he noted “large improvements in BER [bit error rate] performance in a flat Rayleigh fading environment.” He commented that “the averaging ability of the OFDM system, which makes the bursty Rayleigh channel appear nearly Gaussian, provides this large BER improvement.”

The other major two-way wireless applications of OFDM include WiFi (IEEE 802.11a, available from standards.ieee.org/getieee802/802.11.html), in which a 64-point transform is standard with only 48 of the subbands used, and in WiMAX (IEEE 802.16) where the DFT may have as many as 4096 points, or as few as 128, to accommodate channels ranging from the nominal 20 MHz down the order of 1 MHz. Researchers have explored how OFDM can be utilized in a multiple access system (OFDMA) (mentor.ieee.org/802.22/file/05/22-05-0005-01-0000-ofdma-tutorial-ieee802-22-jan-05.ppt) where corrections must be made for the different downlink channels to different users [30], and for the differences in delay, amplitude, and phase among the spatially distributed contributions in the uplink channel. Cognitive radio systems

(Continued on page 34)

Equation 3 comes from the mathematics of singular value decomposition [24], which demonstrate that a matrix is diagonalized if it is postmultiplied by the matrix whose columns are its eigenvectors, and premultiplied by the conjugate transpose of that eigenvector matrix. It is a remarkable fact that the eigenvector matrix for *any* circulant matrix (which can be generated from any channel characteristic) is always the same and is simply the matrix whose columns are the powers of the N th root of one (i.e., the matrix that defines the DFT). If H_C is our channel circulant matrix, F_1 is the IDFT matrix, and F_2 is the DFT matrix (the complex transpose of F_1), then $F_2 H_C F_1$ is the diagonal matrix Λ whose elements are the eigenvalues of H_C . These can be shown to be the values of the channel transfer function at the discrete subchannel frequencies. The data can be recovered from the output samples in Eq. 3 by simply dividing each element of the output vector by the appropriate value of the channel transfer function.

The high peak to average power ratio (PAPR) of OFDM was as serious a problem as intersymbol interference. An intuitive example is when the same modulation level is used for all the subcarrier sinusoids; at $t = 0$ they will all have the same polarity and add up to a large value. High peak values occur infrequently but can be very high. For example, for an unmodified 256-point OFDM signal, Han and Lee computed

that the peak-to-average ratio exceeds 11.3 dB for less than 0.1 percent of the OFDM data blocks [25]. They discuss a number of approaches to limiting peak-to-average power including amplitude clipping, coding, tone reservation or injection, dynamic constellation extension, and various signal formation techniques such as mapping and interleaving, which will not be described here. Greenstein and Fitzgerald contributed early work on signal phasing to minimize high PAPR [26].

OTHER APPLICATIONS

ADSL was the first widely used application for FFT-based OFDM, but the predecessor of another application, OFDM-based frequency-hopping systems, was a 1942 patent of Hedy Kiesler Markey, better known as the film star Hedy Lamarr [27]. The objective, during World War II, was a jam-resistant communication channel for guiding torpedoes, and Lamarr’s solution was random movement among frequency channels that would thwart the narrowband jamming systems. Although the system of Fig. 15 used a tunable hardware oscillator rather than a DFT, it illustrated one more motivation for generating a signal utilizing many subchannels rather than a single-carrier system.

The concept of frequency hopping is now a popular spread spectrum technique for avoiding interference if not

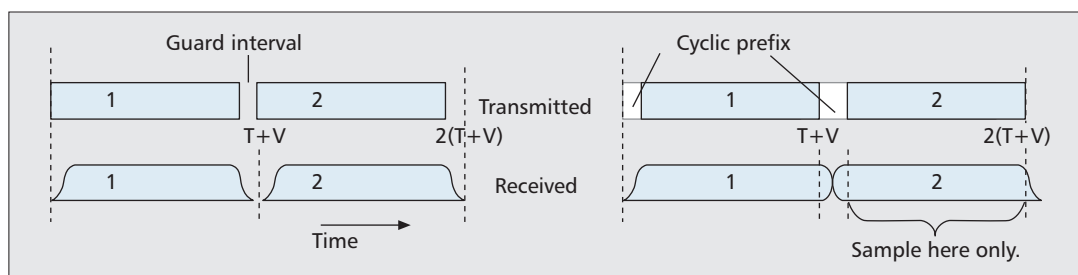

Figure 14. Transmission of OFDM pulses with guard interval and with a cyclic prefix.

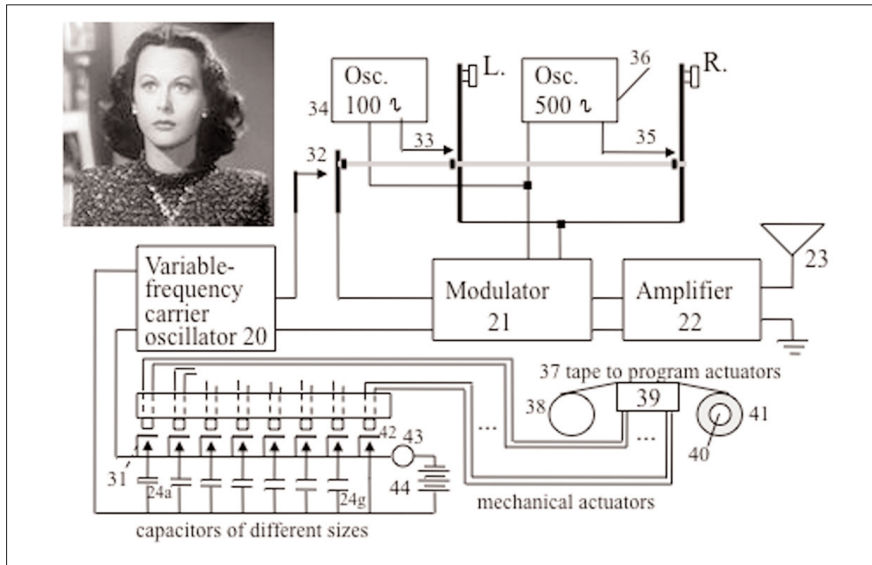

Figure 15. Part of the figure from the frequency-hopping system [27] co-invented by Hedy Lamarr (photo).

(Continued from page 32)

are a significant application area [31].

OFDM is associated with one of the major newer application areas of OFDM, audio and video broadcasting, as exemplified by Sari and Karam's analysis of the application to cable television systems [32] and the terrestrial broadcast (DVB-T) work of Reimers [33]. The DVB-T broadcaster (Fig. 16) uses a 2048 ("2K") or 8192 ("8K") DFT and employs coded OFDM (COFDM) [34]. The serial baseband bitstream is distributed over multiple subbands for robustness against multipath channels and against narrowband interferers. A lengthened guard interval, up to one fourth the OFDM symbol length, provides added protection at the cost of lower spectral efficiency. Spectral efficiency ranges from 0.62 bits/sec/Hz to

3.27 bits/sec/Hz, in an 8 MHz channel, depending on the code rate (1/2 to 7/8) and the modulation (QPSK, 16-QAM, 64-QAM). DVB has been extended to a more mobile-friendly version, DVB-H (handheld), that has been adopted as a standard of the European Union. The standard ("8K") version of DVB-H employs an 8192-point DFT but only uses 6817 active subcarriers spaced by 1.116KHz, of which 6048 carry user data [www.dvb-h.org/PDF/DVB-H Fact Sheet.0808.pdf] [35]. A "4K" mode is also available in DVB-H but not in DVB-T.

Within the past several years, OFDM has been applied to long-haul optical communication networks, where it can help reduce the degradations of chromatic dispersion [36]. The newest application area in optical communications is in local access, for example in

PONs (passive optical networks), where the fine granularity of the subbands provides many opportunities for configuring a range of services and virtual private networks [37].

An additional new application area is in ultrawideband (UWB) personal area networks using OFDM. In this application (IEEE 802.15.3a), the spectrum is segmented in 528 MHz chunks, each supporting 128 OFDM subchannels. A communication session can jump among chunks and subchannels from one OFDM symbol to the next.

WHERE CAN IT GO NEXT?

OFDM does not necessarily have to use sinusoidal carriers. There has been exploratory work in the use of prolate spheroidal [38] and wavelet [39] transforms. We are likely to see it appear in many forms to meet different needs. It will continue to have competition with alternatives [40]. OFDM is one of those techniques that had to wait quietly for generations until technology made it practical. As computational technology continues to advance, and with lower-power "green radio" becoming an important goal, we can expect even more innovative applications in the near future.

REFERENCES

- [1] K. G. Beauchamp, *History of Telegraphy*, IEE, 2001, p. 394.
- [2] U.S. patent 174,465, "Improvement in Telegraphy," Alexander Graham Bell, Mar. 7, 1876.
- [3] U.S. Patent 166,095, "Electrical Telegraph for Transmitting Musical Tones," Elisha Gray, July 27, 1875.
- [4] U.S. Patent 182,996, "Acoustic Telegraph," Thomas Edison, Oct. 10, 1876.
- [5] M. Schwartz, "The Origins of Carrier Multiplexing: Major George Owen Squier and AT&T," *IEEE Commun. Mag.*, May, 2008, pp. 20-24. Original paper: G. Squier, "Multiplex Telephony and Telegraphy by Means of Electric Waves Guided BY Wires," *Trans. AIEE*,

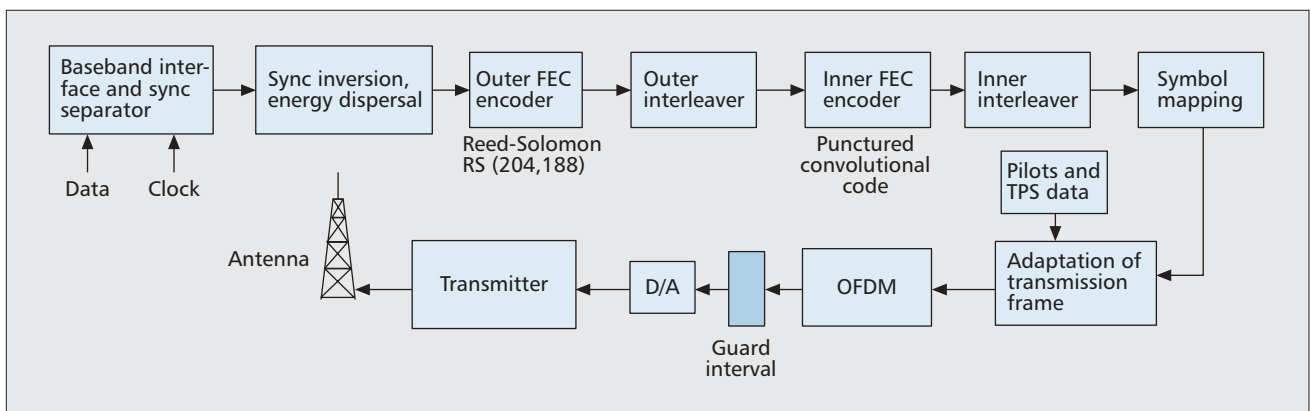

Figure 16. The DVB-T system [34].

- vol. 30 pt. 2, 1911, pp. 1675–80.
- [6] H. Boyd and F. Herr, "The N2 Carrier Terminal — Objectives and Analysis," and W. Lundry and L. Willey, "The N2 Carrier Terminal Circuit Design," *Bell Sys. Tech. J.*, vol. 44, no. 5, May–June 1965, pp. 731–85.
- [7] S. B. Weinstein and P. M. Ebert, "Data Transmission for Frequency-Division Multiplexing Using the Discrete Fourier Transform," *IEEE Trans. Commun. Tech.*, vol. 19, no. 5, Oct. 1971, pp. 628–34. An earlier publication was J. Salz and S. B. Weinstein, "Fourier Transform Communication System," *Proc. ACM Conf. Comp. and Commun.*, Pine Mountain, GA, Oct. 1969.
- [8] R. W. Chang, "High-Speed Multichannel Data Transmission with Bandlimited Orthogonal Signals," *Bell Sys. Tech. J.*, vol. 45, Dec. 1966, pp. 1775–96; see also U.S. Patent 3,488,445, Jan. 6, 1970.
- [9] B. R. Saltzberg, "Performance of an Efficient Parallel Data Transmission System," *IEEE Trans. Commun. Tech.*, vol. 15, no. 6, Dec. 1967, pp. 805–11.
- [10] R. W. Chang and R. A. Gibby, "A Theoretical Study of Performance of an Orthogonal Multiplexing Data Transmission Scheme," *IEEE Trans. Commun. Tech.*, vol. 16, no. 4, Aug. 1968, pp. 529–40.
- [11] B. Hirotsaki, "An Orthogonally Multiplexed QAM System Using the Discrete Fourier Transform," *IEEE Trans. Commun.*, vol. COM-29, no. 7, July, 1981. See also "An Analysis of Automatic Equalizers for Orthogonally Multiplexed QAM Systems," *IEEE Trans. Commun.*, vol. COM-28, no. 1, pp. 73–83.
- [12] H. Bolcskei, P. Duhamel, and R. Hleiss, "Design of Pulse Shaping OFDM/OQAM Systems for High Data-Rate Transmission Over Wireless Channels," *Proc. ICC 1999*, pp. 559–64.
- [13] M. S. Zimmerman and A. L. Kirsch, "The AN/GSC-10 (KATHRYN) Variable Rate Data Modem for HF Radio," *IEEE Trans. Commun. Tech.*, vol. COM-15, no. 2, Apr. 1967; see also Bellow's earlier but less complete introduction to KATHRYN in vol. COM-13, no. 9, Sept. 1965.
- [14] J. Cooley and J. Tukey, "An Algorithm for the Machine Calculation of Complex Fourier Series," *Math. Comp.*, vol. 19, 1965, pp. 297–301.
- [15] M. Heideman, D. Johnson, and C. Burrus, "Gauss and the History of the Fast Fourier Transform," *IEEE ASSP Mag.*, vol. 1, no. 4, 1984, pp. 14–21.
- [16] H. Sari, G. Karam, and I. Jeanclaude, "Transmission Techniques for Digital Terrestrial TV Broadcasting," *IEEE Commun. Mag.*, Feb. 1995, pp. 100–09.
- [17] A. Czyliwik, "Comparison Between Active OFDM and Single Carrier Modulation with Frequency Domain Equalization," *Proc. 1997 IEEE VTC*, Phoenix, AZ, 1997.
- [18] S.L. Ariyavisitakul et al., "Frequency Domain Equalization for Single-Carrier Broadband Wireless Systems," *IEEE Commun. Mag.*, 2002.
- [19] U.S. Patent 4,924,492, May 8, 1990, "Method and Apparatus for Wideband Transmission of Digital Signals Between, for Example, a Telephone Central Office and Customer Premises," invented by R. D. Gitlin, S. K. Rao, J.-J. Werner, and N. S. Zervos.
- [20] S. Ahamed and V. Lawrence, *Intelligent Broadband Multimedia Networks*, Springer, 1997.
- [21] J. Bingham, "Multicarrier Modulation for Data Transmission: An Idea Whose Time Has Come," *IEEE Commun. Mag.*, vol. 2, no. 5, May, 1990, pp. 5–14.
- [22] K. Sistanizadeh, P. Chow, and J. Cioffi, "Multi-Tone Transmission for Asymmetric Digital Subscriber Lines," *Proc. IEEE ICC*, 1993, vol. 2 pp. 756–60.
- [23] R. Peled and A. Ruiz, "Frequency Domain Data Transmission using Reduced Computational Complexity Algorithms," *Proc. IEEE Int'l. Conf. Acoustics, Speech, and Sig. Proc.*, 1980, Denver, CO, pp. 964–67.
- [24] V. Madisetti and D. Williams, *Digital Signal Processing Handbook*, IEEE Press and CRC Press, 1998.
- [25] S. Han and J. Lee, "An Overview of Peak-to-Average Power Ratio Reduction Techniques for Multicarrier Transmission," *IEEE Wireless Commun.*, vol. 12, no. 2, Apr. 2005, pp. 56–65.
- [26] L. Greenstein and P. Fitzgerald, "Phasing Multitone Signals to Minimize Peak Factors," *IEEE Trans. Commun.*, vol. 29, no. 7, 1981, pp. 1072–74.
- [27] U.S. Patent 2,292,387, H. Kiesler Markey et al., "Secret Communication System," Aug. 11, 1942.
- [28] M. Corson, "A New Paradigm for IP-Based Cellular Networks," *IEEE IT Professional*, vol. 3, no. 6, Nov.–Dec. 2001, pp. 20–29.
- [29] L. Cimini, "Analysis and Simulation of a Digital Mobile Channel Using Orthogonal Frequency Division Multiplexing," *IEEE Trans. Commun.*, vol. 33, no. 7, July, 1985, pp. 665–75.
- [30] D. Kivanc and H. Liu, "Subcarrier Allocation and Power Control for OFDMA," *Proc. 34th Asilomar Conf. Sig., Sys. and Computers*, Oct. 2000, pp. 147–51.
- [31] F.-S. Chu and K.C. Chen, "Radio Resource Allocation in OFDMA Cognitive Radio Systems," *Proc. IEEE PIMRC '07*.
- [32] H. Sari and G. Karam, "Orthogonal Frequency-Division Multiple Access and its Application to CATV, Networks," *Euro. Trans. Telecommun.*, vol. 9, no. 6, Nov.–Dec. 1998, pp. 507–16.
- [33] U. Reimers, "Digital Video Broadcasting," *IEEE Commun. Mag.*, vol. 36, no. 10, June, 1998, pp. 104–10.
- [34] B. LeFloch, M. Alard, and C. Berrou "Coded Orthogonal Frequency Division Multiplex," *Proc. IEEE*, vol. 83, June, 1995, pp. 982–96.
- [35] ETSI EN 302 304: "DVB-H: Transmission System for Handheld Terminals," v1.1.1, Euro. Broadcasting Union, Nov. 2004; dvb-h.org/PDF/DVB-H_percent20Specification_percent20-percent20En302304.V1.1.1.pdf
- [36] W. Shieh et al., "Coherent Optical OFDM: Has Its Time Come?," *J. Opt. Net.*, vol. 7 \$3, 2008, pp. 234–55.
- [37] D. Qian et al., "10-Gb/s OFDMA-PON for Delivery of Heterogeneous Services," *Proc. OFC/NFOEC 2008*.
- [38] T. Marzetta and J. Salz, "Singular Value Decomposition of a Matrix-Valued Impulse Response," *Proc. ICAASP '05*, pp. IV.913–IV.916.
- [39] V. K. Jain and B. Myers, "OWSS: A New Signaling System for 100-150 Mb/s WLANs," *IEEE Wireless Commun.*, vol. 10, no. 4, Aug. 2003, pp. 16–24.
- [40] L. Hanzo et al., *OFDM and MC-CDMA for Broadband Multi-User Communications, WLANs and Broadcasting*, IEEE Press and Wiley, 2003.