

# Lessons from Tesla for Plasma Medicine

David B. Graves, *Member, IEEE*,

**Abstract**—It can be argued that plasma medicine originated with Nikola Tesla in the late 19th century when he showed that one could pass large quantities of high frequency currents through a human body with no apparent damage. Tesla's work inspired much more extensive investigations over a period of several decades by numerous other researchers, on both the physics and biomedical effects of these currents. These early pioneers had a surprisingly modern view of some aspects of the therapeutic mechanisms of high frequency currents that clearly overlap with recent results. The perspective of this community was that the most important physiological effects are associated with the high frequency currents rather than the gas phase plasma *per se*. Some early work, such as the analgesic effects of dielectric barrier air plasma on tissue, is not well known today. The range of afflictions that early practitioners treated successfully is remarkable. This body of work, in some cases almost 130 years old, might have important lessons for current investigations into plasma medicine. Observations from Tesla and other early practitioners suggests that high frequency currents are potentially important and plasma medicine researchers should probably pay more attention to them.

**Index Terms**—Plasma medicine, high frequency therapeutics, history of medicine

## I. INTRODUCTION

The use of electricity for medical purposes has a long history, arguably stretching back into antiquity. [1] [2] Various developments in methods and devices by the first half of the 19th century led to the use of pulsed static electricity ('franklinization'); direct currents ('galvinization') and alternating currents ('faradization') for various, often mysterious and not well understood effects. Even during these early days of electricity and magnetism, medical electricity was controversial and often dismissed as a kind of quackery and fraud. Nevertheless, some legitimately scientific studies of the physiological effects of electricity were initiated after about 1860-70 by various European scientists, principally in Germany and France.

The developments in understanding the physics of electricity and magnetism after about 1880 changed the situation significantly in Europe. By the beginning of the 20th century, there were many centers of electrotherapy throughout Europe, especially Germany and France but also in North America. New scientific journals and societies were created. It was during this period that the use of high frequency currents began to be seriously investigated and it was in this context that the use of what can be described as 'plasma

medicine' was initiated. This is because one of the ways that high frequency electrical currents were coupled to the body was through low temperature, non-equilibrium plasma: corona, brush-like or spark discharges in air. Nikola Tesla is arguably the researcher most responsible for this development and his many contributions in this area are highlighted first in the following section.

The early efforts to apply high frequency electrical currents to medical therapy focused almost exclusively on the effects of the *currents* applied to the body. It was known that the air discharges that often - by design - accompanied application of the current included the formation of gases such as ozone and nitrogen oxides. In the case of ozone, this was thought to have important therapeutic effects. However, the major emphasis and focus was always on the currents. One of the key conclusions from reviewing this literature is that modern plasma medicine may be missing an important element since it has generally ignored or minimized the explicit biomedical role(s) of the currents. This topic and its implications are explored in later sections of the article.

One goal of the present article is to analyze the relation between historical high frequency current therapeutics and the emerging understanding of what is now called plasma medicine. It appears that the historical uses of high frequency currents overlap considerably with plasma medicine and this offers a possible opportunity to advance current efforts.

In addition, the fact that high frequency electrotherapy seems to have mostly disappeared after about 1930 is another fascinating and informative topic. The many reasons for this transition are discussed in the last section of article. It offers both cautionary as well as possibly encouraging evidence that could be useful for the development of plasma biomedical therapy today.

## NIKOLA TESLA

Nikola Tesla, an ethnic Serb, was born in 1856 in the former Austro-Hungarian empire. He was educated there and subsequently emigrated to the United States in 1884. (cf. Fig. 1) He invented and developed a suite of influential electrical and mechanical devices. He became well known to the public for his many inventions, often demonstrating his devices to wealthy individuals and celebrities. His talent for showmanship matched his scientific inventiveness and scientific acumen. By 1890, one of Tesla's inventions was a resonant capacitive-inductive circuit capable of generating pulses at more than 15 kHz and tens of kilovolts. Under the right conditions, these circuits could create impressively large

Department of Chemical and Biomolecular Engineering, University of California, Berkeley, CA 94720 USA  
graves@berkeley.edu

The comments and suggestions of Stephen Reuter and Zoran Petrovich are gratefully acknowledged. This work was partially supported by the US Department of Energy OFES grant DE-SC0001934.

Digital Object Identifier: 10.1109/TRPMS.2018.2866373

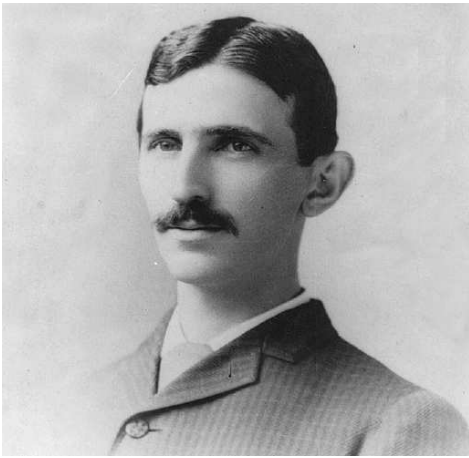

Figure 1 Nikola Tesla as a young man.

sparks in air at atmospheric pressure. Tesla toured North America and Europe in 1892-93, demonstrating his devices and the effects of high frequency currents passing through his body, as shown in the illustration in Fig. 2. [3]

Tesla's circuit is based on coupled primary and secondary transformers, capacitors and a spark gap, shown schematically in Fig. 3. The circuit operates in a cycle with current from the primary transformer coupled to a capacitor, which in turn discharges through a spark gap. This creates a transient, oscillating current in the primary circuit which excites a high oscillating voltage across the secondary coil. An air plasma can be created by the high voltages built up across the ends of the secondary coil. Later, d'Arsonval and Oudin in France improved on Tesla's basic circuit design, as can also be seen in Fig. 3. These circuits and their therapeutic devices are discussed in later sections.

The pulsed oscillations in Tesla's device last on the order of a millisecond. Each spark across the spark gap produces a pulse of damped sinusoidal high voltage across the terminals of the secondary coil. Figure 4 show voltage outputs from the related d'Arsonval and Oudin circuits. These are pulsed (10 kHz), high frequency, high voltage signals. [5]

These circuits - sometimes referred to as 'Tesla coils' - were capable of generating large sparks or brush discharges in air. Tesla was perhaps best known for demonstrating that the currents associated with these discharges could be applied to a living body without apparent damage. Tesla wrote [6],

One of the early observed and remarkable features of the high frequency currents, and one which was chiefly of interest to the physician, was their apparent harmlessness which made it possible to pass relatively great amounts of electrical energy through the body of a person without causing pain or serious discomfort.

Further, he observed that "...these currents would lend themselves particularly to electro-therapeutic uses." [6]

In the early 1890s, Tesla made a series of public demonstrations in the US and Europe that astonished both the public and the scientific world. Tesla described the potential medical use as follows, [6]

This mode of applying high frequency currents in medical treatment appears to me to offer the greatest possibilities at the hands of the physician. The effects produced in this manner possess features entirely distinct from those observed when the currents are applied in any of the before mentioned or similar ways....The only plausible explanation I have so far found is that the tissues are condensers (i.e. capacitors). This only can account for the absence of injurious action.

As noted below in the section of modern treatments of high frequency currents in the human body, the latter observation on the capacitive currents may not be completely correct. However, it may well be that there has never been a serious investigation into the currents induced in a body using a Tesla-like apparatus.

Tesla described the sensations he experienced when high frequency currents passed through his body as follows, [6]

I have repeatedly... exposed myself longer to the action of the oscillations, and each time, after the lapse of an hour or so, an immense fatigue...would take hold of me. I could scarcely make a step and could keep the eyes open only with the greatest difficulty. I slept soundly afterward...

Tesla warned of various dangers if high frequency currents are not properly applied. Among other potential dangers, he notes the creation of potentially noxious gases, [6]

At or near the surface of the skin, where the most intense action takes place, various chemical products are formed, the chief being ozone and nitrogen compounds. The former is itself very destructive, this feature being illustrated by the fact that the rubber insulation of a wire is destroyed so quickly as to make the use of such insulation entirely impracticable. The compounds of nitrogen, when moisture is present, consists largely of nitric acid which might, by excessive application, prove hurtful to the skin.

Of course, the role of reactive oxygen and nitrogen species is now well known to be among the most significant and important of the biomedical mechanisms associated with plasma medicine and related fields. [7]

Tesla also suggested other potential uses for high frequency currents, including heating the body electrically (e.g. under cold conditions and with minimal clothes) or exploiting surgically inserted metal pieces that could be heated rapidly by applied high frequency currents. Neither of these suggestions was implemented, by all accounts. His observation that highly electrified bodies experience rapid removal of dust and other superficially attached small particles also appears not to have

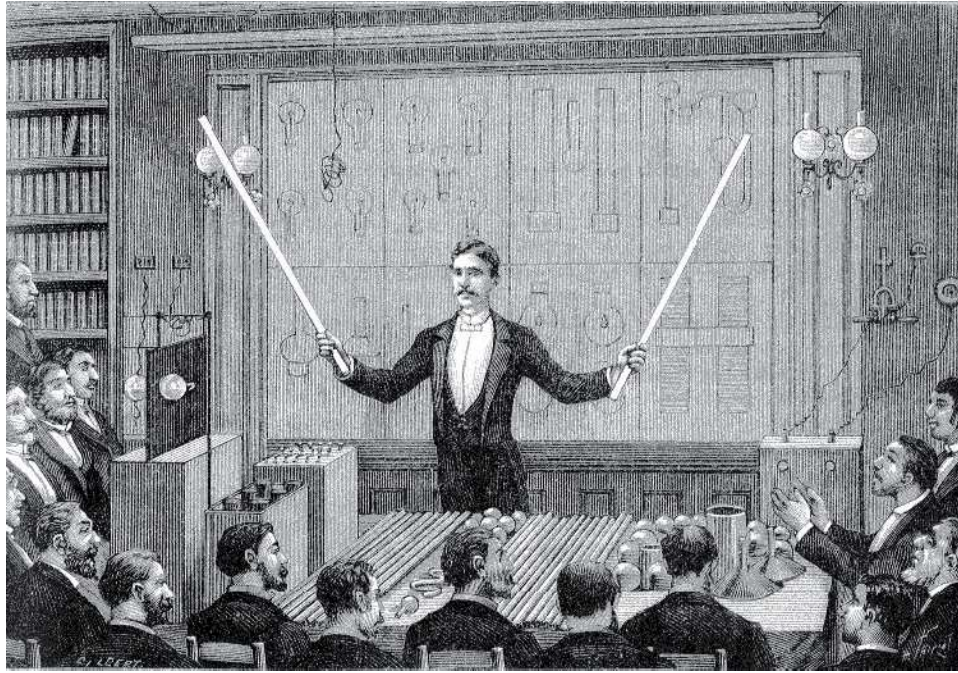

Figure 2 Nikola Tesla shown during one of his 1892-93 public demonstrations of high frequency currents passing through his body and illuminating hand-held evacuated tubes. (Brenni, 2010)

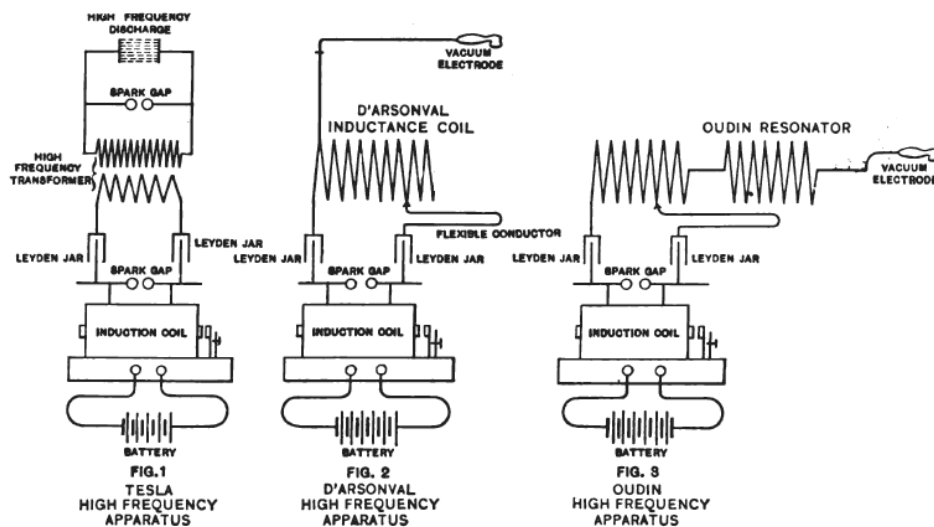

Figure 3 Schematics of circuits used by Tesla, d'Arsonval and Oudin. Each show a dc battery voltage supply connected to an induction coil, with Leyden jar capacitors, spark gaps and some kind of secondary coil or transformer. The Tesla device is shown creating a high frequency discharge in air. The d'Arsonval and Oudin circuits are shown connected to vacuum electrodes, described below. [4]

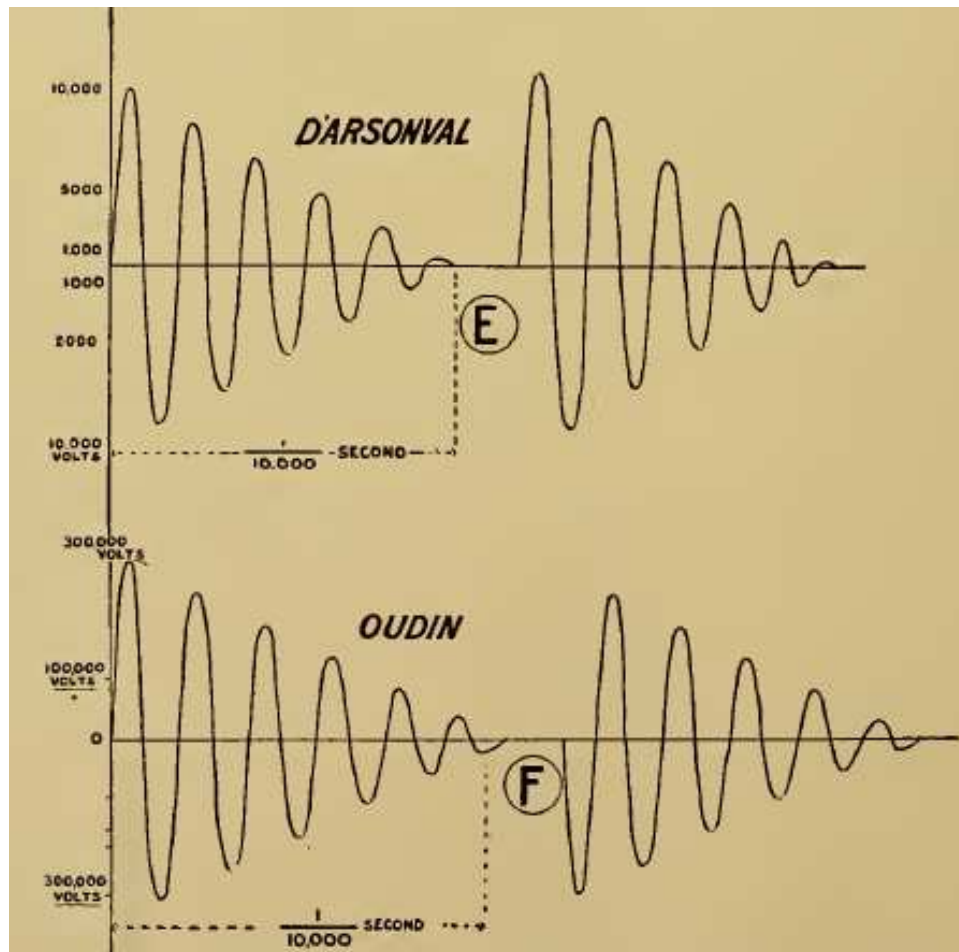

Figure 4 RF currents from d'Arsonval (top) and Oudin (bottom) circuits, similar to Tesla-Thompson circuit, shown in Fig. 3. Note the d'Arsonval device creates a pulsed (approximately 10 kHz), high frequency, high voltage signal. The Oudin device is similar but with a higher output voltage (300kV vs. 10 kV). [5]

been pursued. [8]

Other researchers contributed significantly to this field. For example, at the 1893 World's Fair, Elihu Thomson showed his version of high frequency circuit that created a spark nearly 2 meters in length that could pass through a human body with virtually no apparent damage. Thomson's high frequency (500kHz - 1MHz) currents were reported to be over 10 amperes. Of course, at lower frequency, such currents would likely be fatal. Typical high frequency devices used for therapeutic purposes in the early 1890s were reported to be applied voltages of on the order of 5kV - 500kV at frequencies of 200kHz - 10 MHz. [9]

Interestingly, Tesla himself recognized that he was not trained to judge the best way to take medical advantage of high frequency currents. He wrote the following disclaimer, [6]

I trust that the present brief communication will not be interpreted as an effort on my part to put myself on record as a "patent medicine" man, for a serious worker cannot despise anything more than

the misuse and abuse of electricity which we have frequent occasion to witness...No wonder then that progressive physicians also should expect to find in it a powerful tool and help in new curative processes.

Tesla noted that both the physics and biomedical fields associated with high frequency currents were still very much in their infancy, [6]

But while investigation is being turned in what appears to be the right direction, scientific men are still at sea. This state of things impedes the progress of the physicist in these new regions and makes the already hard task of the physician still more difficult and uncertain.

This observation could still be made today, no doubt. In any case, Tesla left the further development of therapeutic applications of high frequency currents to others.

#### ARSENE D'ARSONVAL

Arsene d'Arsonval was a French physicist, physician, physiologist and engineer. He had been working on understanding the physiological effects of high frequency currents for several years before Tesla's demonstration in

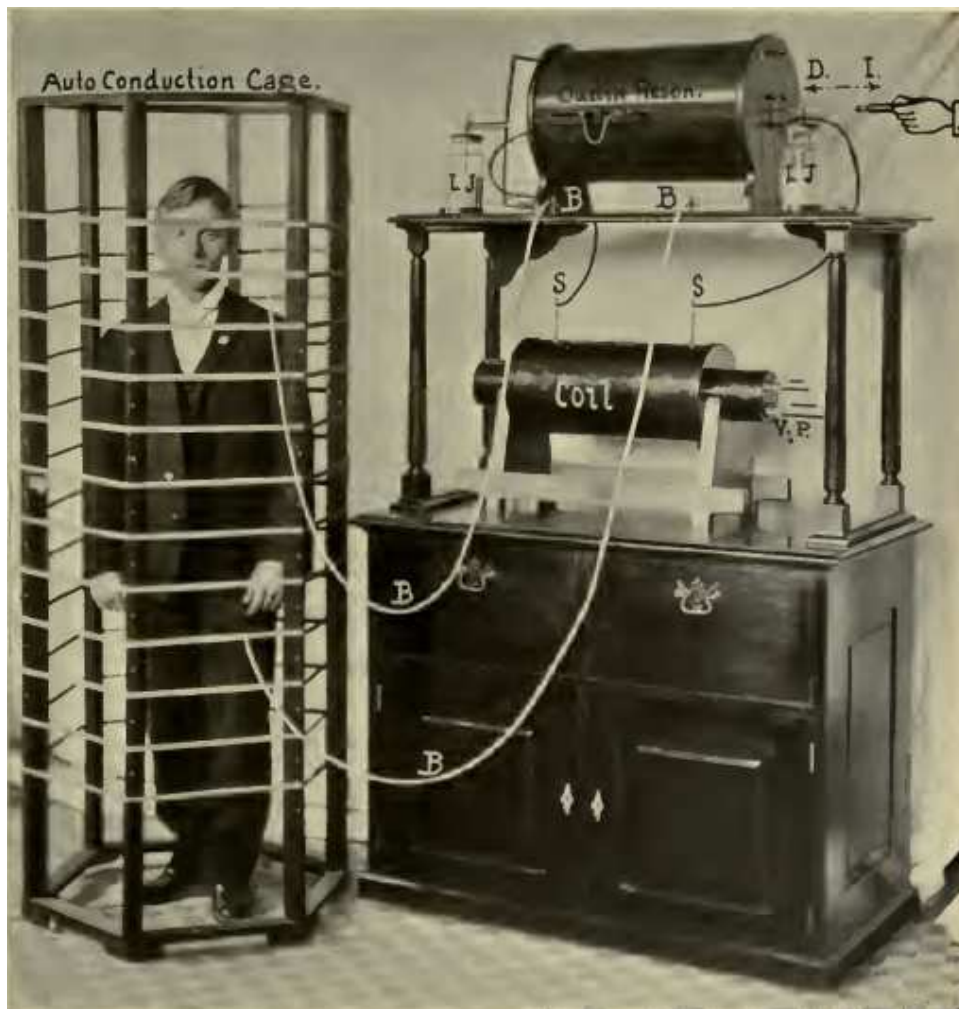

Figure 5 d'Arsonval's device for coupling currents to a body via a large, enclosing induction coil, called 'autoconduction.' [10]

1893. d'Arsonval's devices were based on lower voltage resonant circuits from a design by Hertz. After seeing Tesla's 1893 demonstration in Paris, d'Arsonval developed an alternative circuit that extended Tesla's design and he initiated additional studies using this circuit.

In 1893, d'Arsonval published results showing that it was possible to couple high frequency currents to a human body either with or without direct (ohmic) electrical contact. In one device with no direct contact, d'Arsonval placed the patient to be treated in a kind of cage with a large coil surrounding the patient. This was termed 'auto-conduction,' and is illustrated in Fig. 5. [10] In another device, the person to be treated would recline on a chair, one hand holding a lead from the powered electrode, while the other electrode was placed under the insulating cushion upon which the patient rested. This procedure was termed 'auto-condensation,' and is shown in Fig. 6. [10]

By applying the high frequency current to relatively large areas of the body, the methods of d'Arsonval tended to act in a general, systemic fashion. The primary effects of applying

high frequency currents using one of d'Arsonval's devices were reported to include: [11]

- Increased general metabolism
- Increased glandular activity
- Increased temperature and body heat
- Increased oxidation and hemoglobin
- Increased secretions
- Increased elimination
- Lowered blood pressure when hypertension exists
- Soothing to the nervous system

d'Arsonval, not himself a practicing physician, was sufficiently encouraged by the apparently positive therapeutic results that he wrote the following, [12]

By communicating these facts to physicians, by providing equipment that allows them to get them, my role as physiologist is over. It is now they who correspond to take part in therapy.

Reif-Ackerman [12] points out that the current view of d'Arsonval's work is that it laid the foundation for 'diathermy,' a method to internally heat tissue by the application of external

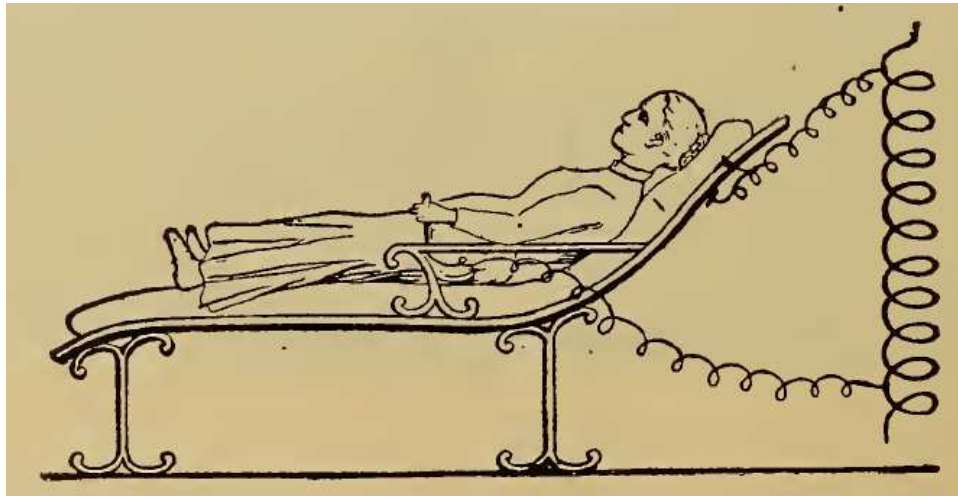

Figure 6 d'Arsonval's device for coupling currents to a body as part of a large capacitor or condenser, termed 'autocondensation'. [10]

high frequency currents. The German physician Nagelschmidt coined the term in 1906 and is generally credited with developing the first practical devices. [8] Nagelschmidt's work on deep heating of tissue established firmly that the RF currents penetrated throughout the organism to which it was applied. [13]

It should be noted that d'Arsonval did not think that the only or even primary cause of the observed physiological effects of high frequency currents was due to heating of tissue. However, by the mid 1940s, this was the prevailing view and it remains the current understanding of most physiologists and physicians. [13] [14]

It remains to be seen if plasma medicine will contradict this view and support d'Arsonval's opinion that the physiological effects observed after application of high frequency currents are primarily non-thermal. This topic has received an enormous amount of attention in the last 50 years or so because of interest in medical diathermy as well as concern about the health effects of RF and microwave radiation. [13] [15] [16] [17] More recent studies on the mechanisms of plasma medicine, (e.g. Kramer et al. [18]) suggest that heating may play a role in plasma-assisted wound healing.

The work of two other pioneers, Paul Oudin in France and Frederick Strong in the US, are summarized in the following two sections. These researchers focused much of their study on devices and operating conditions closer to current plasma medicine practice.

#### PAUL OUDIN

Paul Oudin was a physicist-physician who collaborated with, and was strongly influenced by d'Arsonval's work in the late 19th century. Oudin is best known for the development of an alternative circuit that lent itself especially well to a more localized treatment of high frequency current. This

circuit and device are illustrated in Fig. 7. [10]

Oudin published numerous papers on the therapeutic uses of high frequency currents utilizing various circuits and electrodes, including the one he was best known for inventing. In this article, only two of his many results will be highlighted as they both seem particularly relevant to current therapeutic applications of plasma. He focused primarily on applying the currents *locally* using various forms of air discharges. He used the terms 'spark', 'brush' or 'feather' to characterize the intensity of the air plasma discharge. These discharges could be created using a variety of different electrodes, but by their description, it seems clear that they generally resemble modern non-thermal, typically dielectric barrier-like or corona/spark discharges in atmospheric air.

One could use a single pointed metallic electrode to create a strong spark - this was termed 'fulguration' (in analogy with lightning). Alternatively, multiple small metallic points created a small spray or brush discharge (sometimes referred to as an 'effluve'). Some examples are illustrated in Fig. 8 [10]. This effect could also be created with electrode configurations in which the metallic electrode is covered with a dielectric surface, a configuration that would termed a 'dielectric barrier discharge' in modern parlance. Another related device is the vacuum electrode, described below in the section on Frederick Strong. The action of the effluvia can be seen in the (slightly doctored) photograph in Fig. 9. The doctor is adjusting the Oudin resonator coil with his left hand while applying the effluve to the patient's knee with his right hand. The patient holds the ground or return electrode in his hands to complete the circuit. [19]

One of the most striking results reported by Oudin concerned the fact that the applied current via the air plasma could have an analgesic effect on tissue and thus could be used to treat pain. For these applications, Oudin sometimes used a humid chamois leather as a dielectric between the

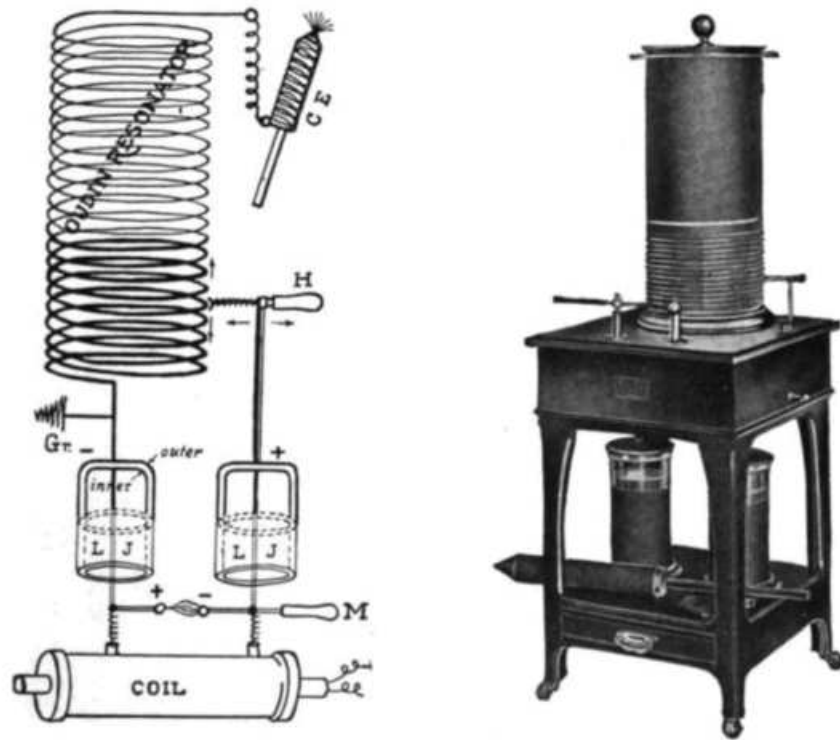

Figure 7 Paul Oudin's circuit (left) and image of device (right). The schematic of the circuit shows a air plasma 'effluve' from the end of the applicator. [10]

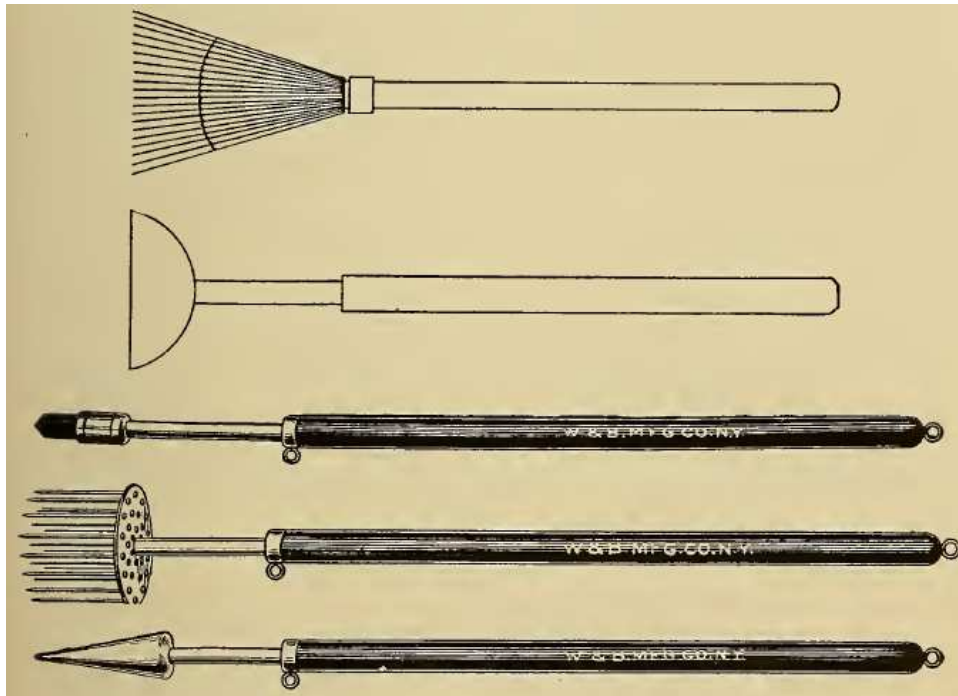

Figure 8 Effluvia electrodes used with Oudin-type devices, showing the single- or multi-point structures. Spark or brush-like air discharges emanate from the tips of these electrodes when connected to the Oudin-like devices. These were termed 'local applications' of high frequency currents. [10]



Figure 9 Partially altered photograph illustrating the effluvia of a patient's knee. The physician is adjusting the 'Oudin resonator' coil with his left hand and applying the electrode with his right hand. The patient is sitting on an insulated platform and holding a ground return electrode in his hands. [19]

metallic electrode and the skin of the patient. He reported that this created a 'rain' of small violet-colored sparks that were not painful. Again, it seems clear that this device acted in a manner that we would term a dielectric barrier discharge today. [20]

Oudin in 1893 reported on a series of treatments on various patients suffering from pain. [20] In one set of cases, he treated lower back pain suffered by 32 manual workers with the high frequency currents. He stated that 10 patients reported that their pain was eliminated after only 1 treatment, 13 patients required 2 treatments, and the remaining 9 required 3 treatments. The treatments lasted between 2-10 minutes on successive days. He had similar successes with other kinds of muscular and nerve-associated pain relief.

However, perhaps the most striking result he reported was associated with pain relief during tooth pulling - normally a very painful procedure. [20] He again used a kind of dielectric barrier discharge arrangement, this time with a moistened cotton layer between the powered electrode and the inflamed tooth that was to be removed. A return electrode, covered with rubber, was used on the outside of the cheek in this application. The air discharge/high frequency currents were applied for 4-5 minutes, after which the tooth was extracted from the patient. After the operation, the patient was interrogated by an individual not associated with the surgeons, to get a more accurate report on the pain experienced during the extraction.

Oudin states that of the 24 patients receiving this treatment, 11 reported no pain experienced during the extraction and 9



reported minimal pain. The 4 remaining patients experienced no analgesic effect, but Oudin notes that the currents were not properly applied to these individuals - either the currents were applied for only 2 minutes, the cotton was too wet, or the electrode was not properly isolated electrically. The book of Monell [9], described below, also emphasizes the role of the 'vacuum electrode' on dental pain relief.

The effects of modern plasma treatment on pain has had only a few references in the current literature. For example, Isbary et al. [21] reported on a study of the use of a cold atmospheric pressure argon plasma device in treating the painful infectious skin condition known as *herpes zoster*. This study reported,

Analysis revealed a significant reduction ( $p < 0.01$ ) in pain in plasma-treated patients compared to controls over the course of treatment, and a significantly better median reduction immediately after each treatment ( $p < 0.05$ ).

More discussion of the reported results from early 20th century physicians for this and related dermatological problems are described in the section on Monell's 1910 book below.

Metelmann et al. [22] reported on a study of 6 patients suffering from squamous cell carcinoma of the head and neck, and treated with the KinPen Med (Ar plasma jet) device for palliative care. (This device is shown in Fig. 15.) [23] Of the 6 patients treated, 4 requested less pain medication following plasma treatments, so there seemed to be some measure of pain relief. However, much more work needs to be done to explore this important topic with different devices and a specific focus on the possible analgesic effects of the plasma.

This is especially relevant since several years earlier, another paper reported antimicrobial killing comparisons between a KinPen Med device and a historical 'violet wand' device that has some aspects in common with the DBD air plasma used by Oudin and colleagues. [24] As noted in greater detail below, these authors state that the historical DBD device (actually a vacuum electrode device) and the modern devices they tested had comparable rates of bacterial killing *in vitro*. Hence, there are good reasons to conclude that the biomedical effects of the DBD air plasma used by Oudin is relevant to modern plasma medical devices.

In a separate paper published in 1910, Oudin reported on a series of gynecological treatments for women suffering from, among other ailments, cervical gonorrhoea, manifested by cervical lesions and other symptoms. [25] The patient to be treated with the high frequency device was attached electrically to ground and the ulcerated cervical surfaces were treated 3 times per week for 6 minutes with a spherical DBD-type electrode covered in glass. Sparks of 1-2 cm were directed towards the ulcerated surfaces. Oudin reported considerable success with this treatment for many related gynecological afflictions.

Finally, it is well worth noting Oudin's opinion of the mechanisms of healing that he observed using the high frequency currents when focused locally on lesions and local infections, (translated from the original French), [25]

In two words, I remind you that I do not believe the high frequency currents are directly microbiocidal, but rather a very powerful modification to the local capillary circulation coupled with an active vascular drainage that stimulates phagocytosis. As regards the pain relief, several theories could be proposed to explain it, but rather than speculate, perhaps we should simply note it and use it.

This observation seems consistent with recent plasma medicine results showing an enhanced sub-cutaneous blood flow following plasma application to mouse and human skin as well as recent results showing plasma can stimulate the immune system. This is discussed in greater detail in the section below regarding mechanisms associated high frequency currents and modern plasma medicine devices.

It should be noted that Crook in his 1909 book [26] reported that other researchers (cited below) *did* see clear evidence of strong antibacterial effects with local application of 'effluvia' or brush discharges in air.

In any case, the therapeutic effects reported by Oudin seem directly relevant to plasma medicine today. Furthermore, these results raise the question - are we missing some important applications by ignoring or minimizing the action of the RF current associated with plasma treatment?

#### FREDERICK F. STRONG

Frederick Strong was an American physician (and by necessity, electrical engineer) who was one of the leading pioneers in the use of high frequency currents for therapeutics. He wrote a book entitled 'High Frequency Currents,' published in 1908 (with a second edition in 1918) that is one of the more accessible of the early works published in English. [10] In his 1908 book, Strong claims to have invented the vacuum electrode in 1897, well before its common use in Europe in about 1900. Strong writes the following [10],

From the first, the writer administered the current by connecting the patient to the terminal of his Tesla coil by means of a metal hand electrode, the opposite pole being connected with the various devices for causing the discharge to play upon the affected areas of the patient's body. A few accidents, in which the electrode was carried too near the body (causing a painful spark), led to the employment of a tube of glass between the patient and the active electrode. It was but a step to substitute for the glass-covered metal electrode (*i.e. a DBD configuration*), a Geissler vacuum tube, in which the current passes through the body via the glass walls of the tube and the rarefied gas that it contains. This led to the invention of the *Vacuum Electrode*, a device now

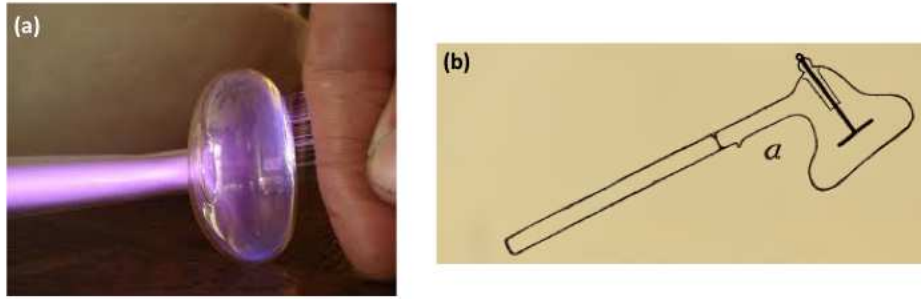

Figure 10 (a) Photograph of modern version of vacuum electrode - a low pressure glass enclosure with an inserted powered electrode (not visible) creating a low pressure glow discharge inside the enclosure - coupled to an external dielectric barrier discharge in air between glass and skin; (b) Sketch of one of Strong's vacuum electrodes, with insulated handle. The similarity of the two devices is obvious. [10]

universally employed, but which was first devised by the writer in 1897.

Figure 10(a) is a photograph of a modern version of a vacuum electrode (aka. 'violet ray' or 'violet wand') and Fig. 10(b) is a schematic of a vacuum electrode device from Strong's book. [10] When the vacuum electrode is held away from the surface, one sees the discharge between the surface of the glass and the body. Figures 11 and 12 [10] are images showing actual therapeutic application of vacuum electrodes to patients. In both cases, it appears that the glass surface is in contact with the skin of the patient, but air discharges may be occurring between the glass and skin near their mutual point of contact. It is also possible that no air plasma forms and the effects of these devices is confined to photons and rf currents passing to the tissue. It is difficult to say because the importance of an air discharge next to the skin is not always discussed in this early literature.

Strong [10] describes in some detail the effects of lowering the gas pressure inside the modified Geissler (gas discharge) tube, powered by various RF sources, including a Tesla coil and related circuits. The color of the glow discharge changes as pressure is lowered and there are changes to the spatial and temporal patterns of light in the tube. At a sufficiently low pressure and high applied voltage, Strong points out that the device generates X-rays, created when high energy 'cathode rays' (i.e. electrons) impact the anode. Figure 13 illustrates three reduced pressure vacuum electrode designs that Strong notes could be used to generate X-rays for either diagnostic of therapeutic purposes. [10] At intermediate pressures and voltages, he was aware that UV light is produced. Of course, this is entirely expected given modern knowledge of gas discharges at reduced pressure.

Strong [10] summarizes his conclusions about the physiological and medical effects of high frequency currents as follows,

- Promotes circulation, increases metabolism and more or less completely restores the general harmony between different functions of the body
- Increases cellular chemical processes, increases the vital combustion both in quantity and intensity
- Facilitates the elimination of waste products
- Increases vaso-motor activity with a slight rise in arterial tension
- Increases oxidizing power of the blood
- Induces germicidal action via ozone

Strong's book strikes the modern reader in a number of ways. First, there is a remarkably large number of different circuits and rather complex devices that were developed and used for high frequency therapy around the turn of the 20th century. This community of physicians/scientists/engineers worked tirelessly to invent, test and document the physiological and medical effects of many different configurations. Second, the book has passages describing basic physics and biology that seem peculiar and even unscientific. For example, from the preface, Strong [10] writes,

In other words, science informs us that all natural phenomena result from VIBRATION in a medium of a primitive nature, which appears to be nothing more or less than Electricity. All forms of force, from the attraction of the Sun for the Earth to the vital phenomena of the Human Organism, are fundamentally Electrical Vibrations.

There is much more along these lines in the book, and Strong was certainly not the only individual in this community of physicians using high frequency currents to try to frame the technology in such improper terms. S.H. Monell,



Figure 11 Photograph of application of vacuum electrode to patient's leg, circa World War I. [27]

described below, in several instances used even more florid descriptions in his book [9]. This characteristic of the field likely contributed to its eventual decline by raising suspicion among other physicians and scientists that proponents of this technology were not really to be trusted. This is described in the last section of the article. It should be mentioned that not all publications during this time used this non-scientific style of characterization to describe and define the use of high frequency electrotherapy. For example, the book of Crook [26] on High Frequency Currents, published in 1909, did not indulge in this style of writing.

In any case, it is probably a mistake to dismiss this body of work because some of the individuals in the field either misunderstood the wider scientific issues or made bold and over-broad assertions about high frequency currents that cannot be supported by scientific analysis. There are multiple aspects of these accounts that support the idea that there is much to learn from this literature. The types and characteristics of air plasma discharges used to transmit high frequency currents to the patients is close, and in some cases virtually identical, to modern plasma medicine devices. Furthermore, the conclusions, albeit somewhat speculative, regarding the mechanisms of high frequency currents and air discharges on the body are sometimes (but not always) remarkably similar to the ones currently supported by modern plasma medicine investigations. This subject is addressed in greater detail below.

Finally, when we compare the reported therapeutic effects of high frequency currents during this period with the relatively few modern results, the overlap is striking.

Daeschlein et al. [24] admirably summarize results from the early 20th century German language literature utilizing high frequency currents. This community in the late 19th century - early 20th century, made many claims of therapeutic efficacy for a wide variety of ailments. Are these many claims all specious? Or is it possible that the modern community has simply not yet re-discovered them?

#### SAMUEL H. MONELL

Samuel Howard Monell, a physician operating in New York City in America, published his book entitled "High Frequency Electric Currents in Medicine and Dentistry" in 1910. [9] The book suffers from some of the same problems as Strong's book in that it attempts to characterize high frequency currents applied to living bodies in what would seem to be an over-broad manner. However, there are many anecdotal descriptions from a large group of physicians throughout the English-speaking world of various therapeutic applications of high frequency to patients. These take on added significance because they tend to corroborate each other and in some cases, the modern published results. A few examples will suffice to make this case, but there are many similar reports in the book.

The following set of examples from Monell [9] refer to applications of local high frequency currents to various dermatological conditions. For example, Monell [9] quotes numerous physicians, including Dr. Charles W. Allen, Professor of Diseases of the Skin, Postgraduate Medical School, New York City as follows,

During the past 3 years, I have employed high frequency currents in my office practice in a



Figure 12 Photograph of application of vacuum electrode to patient's shoulder. [10]

somewhat wide range of skin diseases....In chronic eczema, I have found the local application of decided value in alleviating symptoms and in diminishing infiltration. In *lichen planus* not only are the lesions improved at times but the element of itching is relieved...In *zoster* of the thigh and arm with hyperaesthesia and neuralgic pain, not only has temporary relief been afforded, immediately after each treatment, but the whole course of the disease has been shortened and the lesions have healed more promptly than without their use.

This quote is especially relevant in that it cites the effects of high frequency currents on *zoster* (similar to the recent results of Isbary et al. [21]) as well as successful treatments of *lichen planus*. The latter affliction was recently reported to

be successfully treated using the KinPen Med device. [28]

Further, Monell [9] quotes Dr. Allen,

The recorded (175) cases include 37 of *acne*, 26 of *alopecia*, 27 of *eczema*, 8 of *pruritus ani*, 8 of *pruritus vulvi*, 2 of general *pruritus*, 5 of *pityriasis rosea*, 3 of *uticaria*, 4 of *lichen planus*, 1 of *mycosis fungoides*, 3 of *zoster*, 3 of *rosacea*, 2 of *pruritus haemalis*, 1 of *pruritus scroti*,...etc.

The book contains other, similarly positive, descriptions of applications to many other conditions, too numerous to list. When these early 20th century reports overlap with modern accounts, especially for dermatology, they seem quite similar.

Summarizing briefly, Monell [9] reports many positive re-

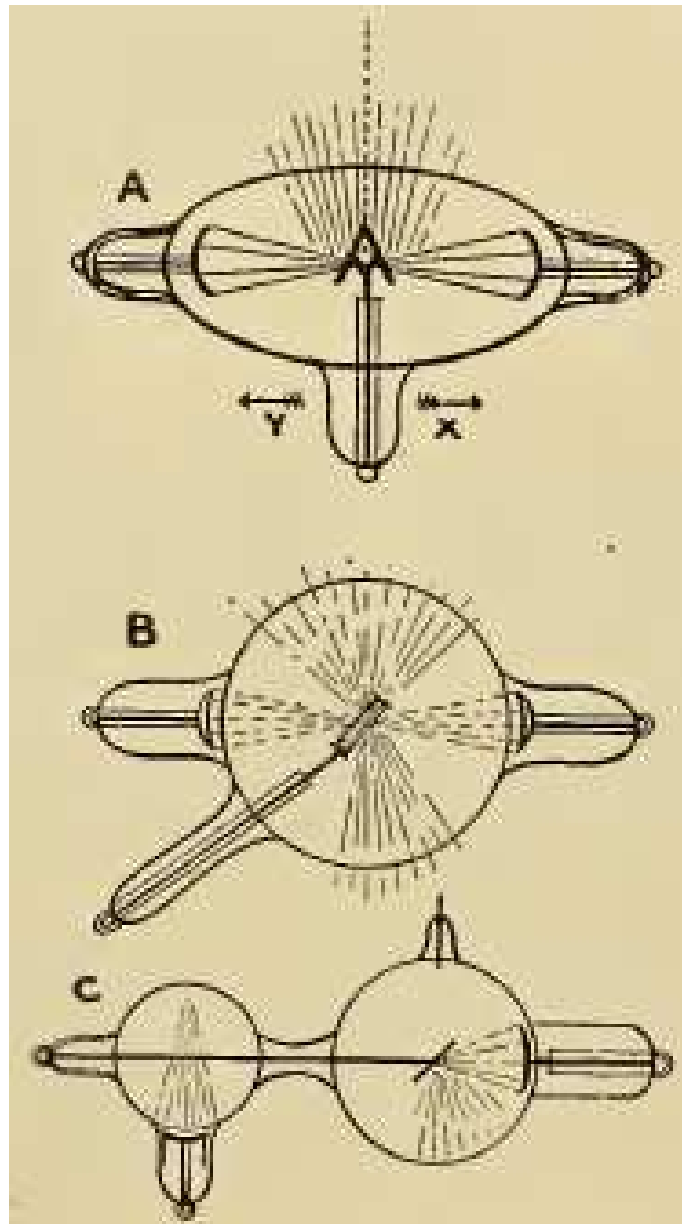

Figure 13 Three sketches of X-ray creating vacuum electrode configurations, all powered by high frequency circuits. Electrons created at powered cathodes accelerate in the very low pressure gas region to impact central, angled anodes, creating X-rays that can be applied for either imaging or treatment. [10]

ports on the therapeutic uses of high frequency currents, in addition to dermatology, include treatments for:

- Diseases of the digestive system
- Diseases of the blood and heart
- Diseases of the respiratory tract
- Diseases associated with metabolism
- Diseases involving the excretory apparatus
- Diseases of the nervous system
- Infectious and malignant diseases

#### HIGH FREQUENCY CURRENTS INTERACTING WITH BIOLOGICAL TISSUE AND CELLS

The previous summary of early 20th century ideas about the effects of high frequency currents on tissue and cells

raises the question of more modern perspectives.

Considerable research has been done since the early part of the 20th century on the topic of high frequency currents interacting with biological systems. Specifically, studies of the interactions between non-ionizing electromagnetic radiation and biological tissue has received considerable attention. (e.g. [15] [29] [30]) Tissue dielectric properties are generally expressed in terms of a complex electric permittivity, including a part that reflects the free motion of ionic charges (conductivity) and the portion that reflects field-induced distortion or polarization of fixed charges, usually associated with cellular membranes (permittivity). The former effect controls tissue conductance and the latter

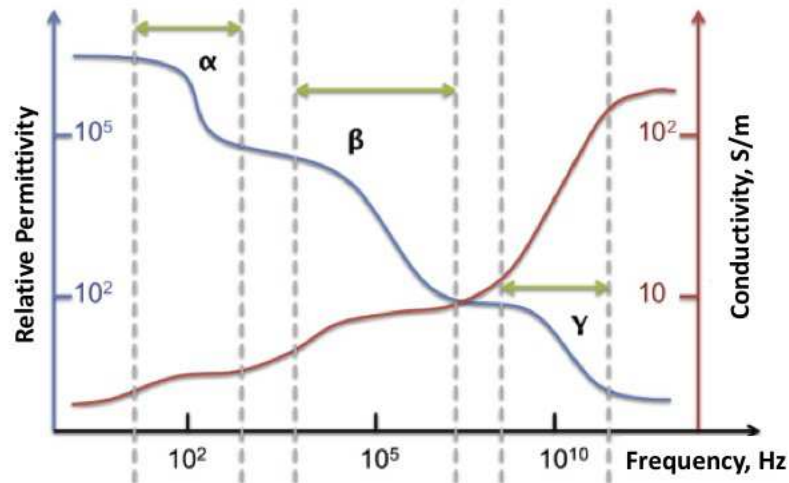

Figure 14 Relative permittivity and conductivity of biological tissue as a function of frequency. The relative permittivity declines with frequency and shows three distinct dispersion regions, due to various relaxation processes associated with cells and the aqueous ionic solutions within which they reside. For details, see text. [31]

effect controls tissue capacitance. The complex permittivity of tissue is frequency dependent (with frequency typically ranging from 10 -  $10^{12}$  Hz), and the dispersion relation (permittivity as a function of applied frequency) can show complex shapes. In general, tissue permittivity declines with applied frequency and conductivity rises up into the microwave region. The question of human body impedances at radio frequencies is addressed below in greater detail.

The typical biological tissue shows 3 frequency transitions, usually termed  $\alpha$  at about  $10^2$  Hz,  $\beta$  at about  $10^5$  Hz and  $\gamma$  at about  $10^{10}$  Hz. This is illustrated in Fig 14. The  $\alpha$  dispersions are associated with diffusion dynamics of mobile charges;  $\beta$  dispersions characterize interfacial polarization across intercellular membranes; and  $\gamma$  dispersions are caused by aqueous content of biological tissue and small molecules dynamics. [31] Tissue conductivity is low at lower applied frequency until it rises into the microwave (GHz) range.

Some of the interest in biological tissue dielectric properties arises from concerns about potential health effects related to low exposure levels caused by electrical power transmission, communication devices like cell phones or microwave appliances. In addition, the use of dielectric spectroscopy of cells and tissues is widespread and there is a need to scientifically interpret these spectra. Also, medical devices used for tissue RF ablation involve high levels of non-ionizing radiation intensity. The electric fields associated with high frequency currents used for the types of therapeutics discussed here are somewhere in the middle of this spectrum of electric field and current intensities.

In the last several decades, considerable progress has been made in understanding the biological effects - including safety issues - of electrical currents in tissue, ranging from 'power

frequencies' (i.e. 60 Hz) through microwave frequencies (10 GHz). (e.g. [32]) Traditionally, the frequency response of a human body to radiofrequency (non-ionizing) radiation has been to assume an ideal resistive-capacitive equivalent circuit. The most common equivalent circuit assumes a lumped skin capacitance of about 200 pF in parallel with a lower limit of lumped skin resistance of about 1.5 k $\Omega$ , in series with an interior body resistance of about 0.5 k $\Omega$ . For frequencies above about 100 MHz, body inductance and electromagnetic effects can be significant. [33] Lumped parameter equivalent circuit models can capture macroscopic electrical responses fairly accurately, but they can't address where the power is deposited in the body and other important details.

In response to this need, starting in the mid- to late-1990s, realistic models of a human anatomy appeared. [34] The models have been used for radiography, radiotherapy (radiation therapy), nuclear medicine and electromagnetic effects. They are sometimes referred to as 'voxel' models and they typically have mm-scale spatial resolution. A voxel is defined as a three-dimensional pixel. For studies of electromagnetic effects, these models consist of solving for the electromagnetic current flows on and through bodies using various numerical methods, for example 'finite difference time-dependent', or FDTD, simulations. Models of parameterized, frequency-dependent dielectric permittivities appropriate for each body component (skin, muscle, bone, blood, organs, etc.) are incorporated in these models.

One example of 'RF dosimetry' simulation under conditions not too dissimilar from plasma medicine are electrostatic discharges (ESD) from human bodies. (e.g. [35] [36] ESDs are of interest in many industrial contexts (e.g. for protecting semiconductor and other sensitive electronic devices) as well as for questions of health and safety regulations.

The 3-D voxel models described above have been used to simulate how electrostatic charge distributed on a human body will flow to and through an air spark to a grounded surface. For example, Hirata et al. [36] used a FDTD voxel model of a human male, female and child to examine how a spark ESD deposits energy into various parts of the body. One result of this class of model is that currents last for hundreds of nanoseconds and that currents (mainly conduction currents) flow through muscle, bone and other biological tissues. [37] Furthermore, relatively simple 'human body models' that use a lumped capacitance of about 200 pF and lumped resistance of about 2 k $\Omega$  are reasonably accurate for macroscopic electrical properties during the ESD.

This kind of voxel modeling of applied currents from plasma medicine devices has apparently not yet been attempted. Given the likely importance of high frequency currents in these applications, perhaps it would be an approach that Tesla might have recommended if he were alive today.

#### LIKELY ROLE OF PULSED ELECTRIC FIELDS IN DIRECT PLASMA-TISSUE INTERACTIONS

The most straightforward analyses of bioelectric phenomena employ passive biological tissue models - that is, the dielectric properties of the biological tissues are assumed to be independent of field intensity. RF diathermy application analysis should be able to make this approximation with few problems. In these applications, tissue temperatures rise to no more than 43-45C. [15] However, even if the *macroscopic* tissue dielectric properties are unaltered with applied currents used in therapeutics (either historic or modern), the *biological effects* of these currents might be significant or even dramatic.

Hanna et al. [38] point out that since about the mid-1960s, it has been known that pulsed electric fields (PEFs) will cause biological cells to form pores - or 'electroporate.' [39] (Note that the external cell membrane is termed the 'plasma membrane,' with no connection to the term 'gas plasma' associated with ionized gas plasma.) The approximate conditions needed to achieve this effect include an electric field strength of about 1000 V/cm with pulse lengths on the order of hundreds of microseconds. For example, this process allows the transfer of DNA from outside to inside a cell subject to the pulsed field (gene transfection). PEF electroporation is currently used for gene therapy, electrochemotherapy, tumor ablation, and even in food processing. Under these conditions, mobile ions both inside and external to the cell have enough time and sufficient mobility to add charge across the plasma membrane, leading to an increase in the transmembrane potential difference. This in turn leads to a permeabilized plasma membrane (PM). [38]

If the pulses are shorter - on the order of a few to hundreds of nanoseconds - and fields are larger (about 300 kV/cm) ions cannot respond to add to the charge difference across the PM. But in this case, the internal parts of the cell are no longer protected from the applied field and the PM as

well as internal organelle membranes can be electroporated. Note these pulsing regimes are consistent with Fig 14: 100 microsecond pulses are between  $\alpha$  and  $\beta$  dispersions and 100 nanosecond pulses are between  $\beta$  and  $\gamma$  dispersions.

In fact, it appears that many of the gas discharge plasmas created in air that are applied to tissues create local electric field strengths at the tissue surface that can permeabilize or electroporate cell membranes. Robert et al. [40], for example, measured electric fields on the order of 1-10 kV/cm in rare gas jets in air. Liu et al. [41] measured electric field strengths an order of magnitude higher in DBD discharges. There are numerous examples of papers that report plasma-induced cellular gene transfection as well as plasma-assisted skin permeabilization. In addition to electric field effects, the presence of plasma-generated reactive oxygen and nitrogen species also appear to be significant. The recent papers by Edelblute et al. [42], Gelker et al. [43] and Szili et al. [44] are representative of this body of work.

#### COMPARING HISTORICAL ELECTRO-THERAPY DEVICES AND MODERN PLASMA MEDICINE DEVICES

There are many different types of modern non-thermal plasma medical devices as can be seen in numerous recent reviews. [45] The first non-thermal plasma sources were approved for clinical testing (i.e. received 'CE certification' in the European Union) in 2013. The 'kINPen MED' (neoplas tools GmbH, Greifswald, Germany) is an RF powered (1 MHz) Ar jet (cf. Fig. 15). The 'MicroPlasSter' (ADTEC, Hunslow, UK) is a microwave (2.45 GHz) powered Ar-plasma torch. Both devices are operated in such a way that there is no significant thermal heating of treated tissue. The 'PlasmaDerm' device (CINOGY GmbH Duderstadt, Germany) operates as a dielectric barrier discharge in open air and is also non-thermal (cf. Fig. 16). [45] [23]

As noted previously, one recent paper directly compared the antimicrobial effects of a historical vacuum electrode device (sometimes called 'violet ray' or 'violet wand') with devices similar to the one shown in Figs. 15 and 16. [24] These results are consistent with observations reported in the 1909 book written by Crook [26] on the antimicrobial effects of brush ('effluve') discharges in air, noted below. In their comparison of historical and modern devices, Daschlein et al. [24] concluded their investigation with the following observation,

In short, VW (*i.e. historical violet wand*) did not differ relevantly from the modern CAPP (*i.e. cold atmospheric pressure plasma*) sources in terms of antimicrobial activity. This potentially clinically beneficial effect is not attributable to a purely psychosomatic or suggestive effect (mystic light show) of the device.

The Violet Ray or Violet Wand device was sold all over the world, apparently starting after the first decade of the 20th century, and continuing well into the 1950s around

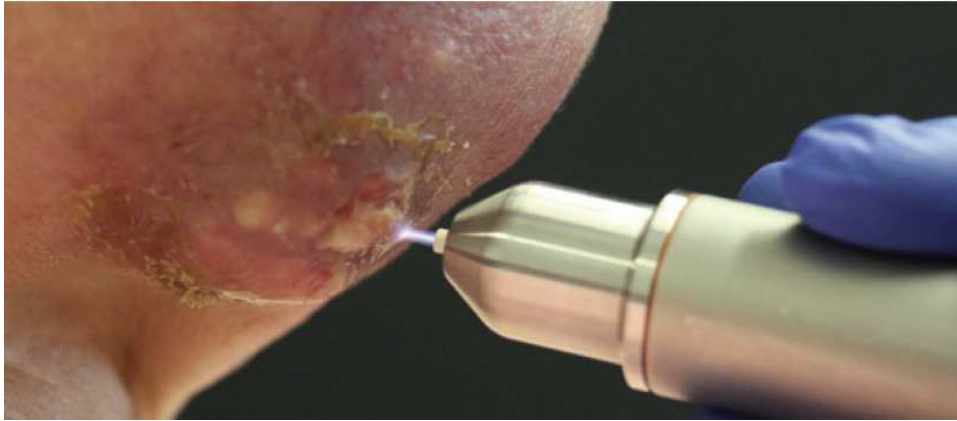

Figure 15 The kINPen MED device utilizes a jet of Ar gas and a RF-powered plasma at 1 MHz. In this image, the jet is used to treat a contaminated cancerous ulcer of the skin on the neck of a patient. [45]

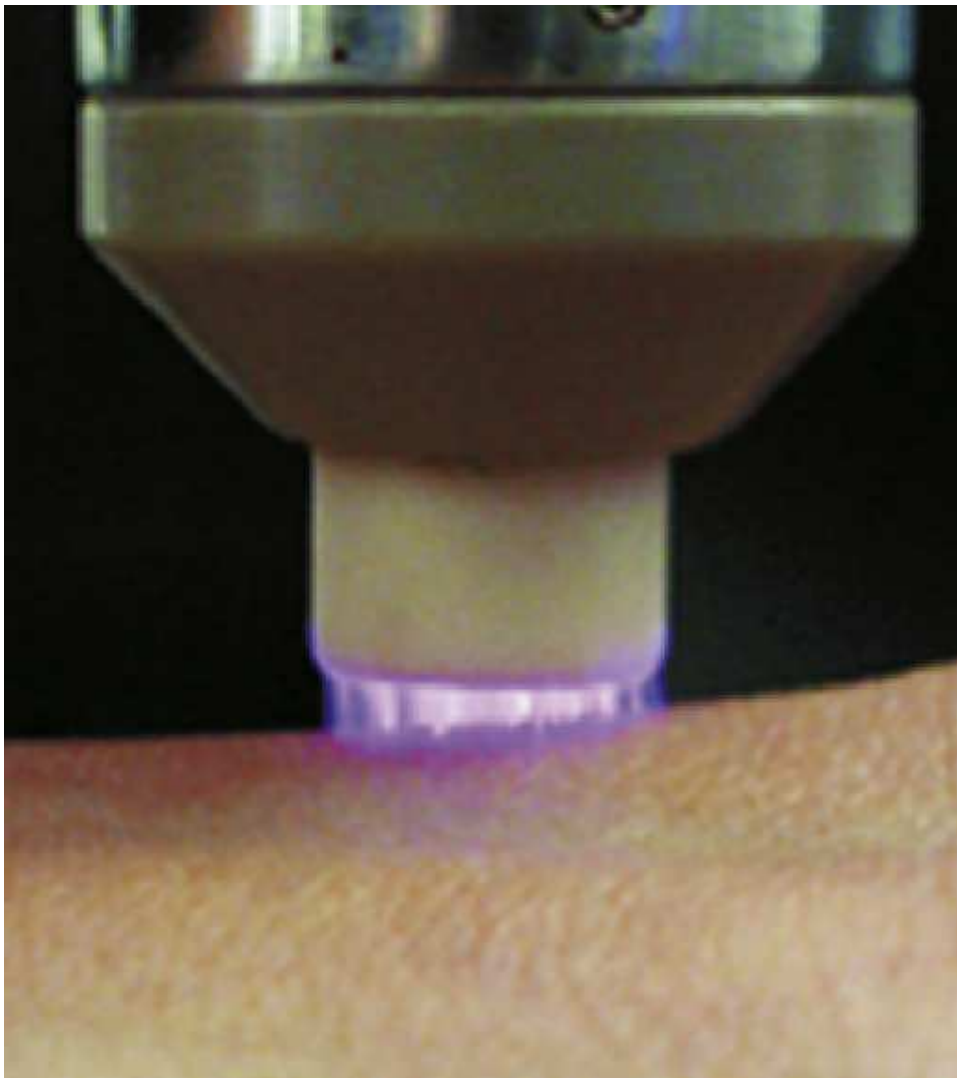

Figure 16 Dielectric barrier discharge in air treating human skin. This device is similar to the commercial 'PlasmaDerm' device. [46]



the world. ([3] [24]) Although the medical value of this type of device was probably oversold by manufacturers and also undoubtedly improperly utilized by unscrupulous and/or untrained individuals, the similarities of these devices with modern plasma medical devices is undeniable.

There are many different types of plasma devices currently under investigation and some of these devices and processes are not necessarily close to the historical devices. For example, treating liquids such as cell culture media with plasma and subsequently applying this treated media to cells or organisms is not close to historical devices. However, the modern plasma devices that involve plasma in contact with cells, tissue or organisms are clearly comparable to historical devices that utilized local high frequency current treatment such as the vacuum electrode, other DBD-like configurations and the spark, brush, or corona discharges.

#### MECHANISMS OF HIGH FREQUENCY THERAPEUTICS AND PLASMA MEDICINE

To a modern reader, one of the most striking aspects of the historical high frequency therapeutics literature is the discussions regarding likely mechanisms. Some of these have been summarized in previous parts of the article. The modern plasma biomedicine researcher might be tempted to separate the effects of the large area electrode treatments associated with d'Arsonval from the local treatments that employed air plasma, such as the vacuum electrode or the direct spark or brush discharge in contact with skin or tissue. The high frequency therapeutics historical community tended to think that the key physical phenomenon was the applied current, and that was present in both the local and d'Arsonval treatments.

As noted above, Oudin in 1893 summarized his view that the therapeutic effects of the DBD-type devices he used were related to "...a very powerful modification to the local capillary circulation coupled with an active vascular drainage that stimulates phagocytosis." [20] Remarkably, this suggestion incorporates two of the most recent mechanisms proposed in the modern plasma medicine literature.

Oudin did not report evidence of direct antibacterial effects of local discharges ('effluviaion'; e.g. as illustrated in Fig. 8). However, other researchers reported strong antibacterial effects when 'effluviaion' (i.e. air plasma) is employed. Crook [26] quotes other researchers (Saler and Papermeister; no citation to the original communication), who claimed,

We are convinced that effluviaion, rather than auto-conduction, is *par excellence* the mode of treatment to be adopted in the treatment of diseases of bacterial origin; ...effluviaion... directly retards the germs themselves and often effects their destruction.

Regarding effects on the blood, d'Arsonval concluded, among other effects, "increased oxidation and hemoglobin" as one of the key effects of high frequency currents. For his part, among other effects, Strong [10] noted "...enhanced

circulation, increased vaso-motor activity with a slight rise in arterial tension, increased oxidizing power of the blood, and induced germicidal action via ozone." Eberhart [11] in his summary of the effects of the use of the vacuum tube included: "increased blood supply to a given area, increased oxidation and local nutrition, increased oxygenation of blood, locally germicidal nature." These authors also included other effects not listed here, but they were generally associated with either nutrition/metabolic changes or promotion of waste elimination.

From the modern point of view, the idea that the applied currents/plasma increase local blood flow was apparently first rediscovered in the 2014 paper by Collet et al. [47] These authors observed a locally increased, subcutaneous flow rate of blood flow in a mouse model treated by a He plasma jet. Blood  $O_2$  content increased significantly as well. Similar observations were made following DBD plasma treatment of the skin of human volunteer subjects by two other groups, (Heuer et al. [48]; and Kisch et al. [49] [50])

Laroussi [51] is generally credited with the first modern observation that atmospheric pressure non-thermal plasma can be highly antimicrobial. However, Cook's 1909 book [26] as well as others in the high frequency electrotherapy community of the early 20th century (e.g. Strong [10]) were aware of this capability much earlier.

The idea proposed by Oudin in 1893 that local treatment with high frequency currents also induced a stronger innate immune response (via phagocytosis) is close to recent proposals, first made by Miller et al. [52] [53] that plasma acts to stimulate the immune system. Oudin seems to have made this suggestion purely on the basis of observing that local infections - such as the gynecological infections that he had experience treating - were fairly rapidly responding to high frequency current treatments.

It can be concluded that the early high frequency electrotherapy community first discovered important therapeutic effects and apparently correctly identified mechanisms more than a century before the modern plasma medicine community!

#### THE DECLINE OF HIGH FREQUENCY THERAPEUTICS

The subject of why high frequency therapy fell from active medical practice by about 1930 is particularly interesting. For example, Connor and Pope describe the rise and fall of various electrotherapies in Canada in the late 19th- early 20th centuries. [54] The signs that the field was under a kind of siege was evident even at the height of its popularity. For example, Monell [9] recounts the following anecdote,

A lady present said she knew that electricity could *cure* as she had demonstration of the fact. Just then Dr. X came in and his opinion was asked. He ridiculed the idea, saying it was *absolutely* impossible, sneered at electricity and alluded to it as the

magic cure-all for everything known to exist, from toe-ache to consumption...

This attitude was far from uncommon even during this period. [55] Lisa Rosner in her 1988 essay entitled "The Professional Context of Electrotherapeutics" addresses this issue of the decline of interest in high frequency electrotherapy particularly well. [56] Rosner notes that one of the most important factors in the decline of the popularity of high frequency electrotherapeutics was, somewhat ironically, the rapid rise of interest in X-rays. The irony arises from the fact that initially, high frequency currents and X-rays were generated in the same type of devices. Figure 13 illustrates several vacuum electrode devices that are powered by high frequency currents that were used to generate X-rays. Blondel [57] makes a similar point about the effects of the rise in prestige of X-rays in diminishing the allure of high frequency electrotherapies.

As Rosner [56] points out,

Physicians who had been using electricity could continue to do so, and many of them did. But the glamor as well as the therapeutic and research opportunities of the X-rays took much of the excitement away from their work. Physicians who had been proud of their scientific apparatus found themselves bypassed by new developments, perhaps even considered a little old fashioned.

Another factor that probably contributed to the decline of high frequency therapeutics included the increasingly important role played by pharmaceuticals in medicine. Insulin was developed into a powerful drug to treat diabetes in the early 1920s. Sulfonamide drugs were developed in the 1930s, leading to antibiotics by the early 1940s. This development was indeed a revolution in medicine. In the 1940s, chemotherapeutic agents for cancer were developed and pharmaceutical approaches to medicine became dominant while 'physical therapy' - using physical agents like heat, electricity, sound, light and mechanical manipulation - became less central to modern medicine. Blondel [57] notes that d'Arsonval had envisioned physical therapy - including electrotherapy - as the future of medicine, avoiding 'poisoning' patients with drugs of dubious value. Clearly, this did not happen, at least not in the time frame he imagined.

And it must be acknowledged that the scientific reputation of high frequency therapeutics was probably not advanced when well-known advocates and users of the technology like Frederick Strong [58] made claims like the following,

The author can account for these effects only on the theory that these currents, when of proper frequency, are synchronous with the normal rate of sympathetic nerve vibration, and in this way increase the flow of the mysterious Pranic force through which function and tissue growth are maintained.

#### CONCLUDING REMARKS

The story of the history of high frequency electrotherapeutics and its relation to the modern, emerging

field of plasma medicine is fascinating and complex. Although they were abandoned by most physicians for most therapeutic applications, high frequency electrotherapeutic devices remained in use for physical therapy (diathermy) as well as in surgery. Modern surgery uses multiple types of plasma-based and other high frequency electrical devices, but mostly for thermal ablation purposes.

The question of whether the modern plasma medicine community can benefit from the recognition of the similarities of current and historical practice is still open. The list of diseases claimed to be treatable by early 20th century high frequency currents is long - and some would say, implausibly or even ridiculously long. However, when similar diseases or afflictions (e.g. pain and several dermatological diseases) are treated using modern devices, the apparent similarities in outcome are intriguing. As noted above, is it possible that plasma medicine has simply not yet re-discovered these fruitful applications?

In any case, the plasma medical devices and procedures that are currently utilized in clinical applications benefit tremendously from the extensive scientific studies of the plasma and its interactions with biological systems. Historical high frequency electrotherapeutics used for non-thermal treatments of many diseases was abandoned by the middle of the 20th century in part because the medical community - including physicians, physical scientists and engineers - did not understand the physical, chemical and biological mechanisms that underlie their operation. Furthermore, disreputable, irresponsible and unprofessional individuals and manufacturers allowed the reputation of the devices and procedures to be damaged. The only way forward for plasma medicine is to continue building the solid scientific foundation upon which sustainable medical practice can be built.

#### REFERENCES

- [1] M Rowbottom and C Susskind. *Electricity and Medicine. History of their Interaction*. San Francisco Press, Inc., San Francisco, CS USA, 1984.
- [2] Sidney Licht. *Therapeutic Electricity and Ultraviolet Radiation*. Waverley Press, Baltimore, MD USA, second edition edition, 1967.
- [3] Paolo Brenni. Les courants haute-fréquence apprivoisés travers la d'arsonnalisation et les spectacles publics (1890-1930). *Annales historiques de l'électricité*, 8(1):53, 2010.
- [4] AF Collins. An Easily Made High Frequency Apparatus. *Scientific American Supplement*, 62(1618):25929, 1907.
- [5] Frederick Finch Strong. High-frequency currents. page 320.
- [6] N. Tesla. High frequency oscillators for electro-therapeutic and other purposes. *Proceedings of the IEEE*, 87(7):1282, July 1999.
- [7] David B Graves. The emerging role of reactive oxygen and nitrogen species in redox biology and some implications for plasma applications to medicine and biology. *Journal of Physics D: Applied Physics*, 45(26):263001, July 2012.
- [8] D.J. Rhees. Electricity - "The greatest of all doctors": An introduction to "High frequency oscillators for electro-therapeutic and other purposes". *Proceedings of the IEEE*, 87(7):1277-1281, July 1999.
- [9] S.H. Monell. *High Frequency Electric Currents in Medicine and Dentistry*. William R. Jenkins Company, New York, NY, 1910.
- [10] Frederick Finch Strong. *High-frequency currents*. Rebman, 1908.
- [11] Nobel M. Eberhart. *A Working Manual of High Frequency Currents*. New Medicine Publishing, Chicago, IL USA, 1911.

- [12] Simon Reif-Acheran. Jacques Arsene d'Arsonval: his life and contributions to electrical instrumentation in physics and medicine. part iii: high-frequency experiences and the beginnings of diathermy [scanning our past]. *Proceedings of the IEEE*, 105(2):394–404, February 2017.
- [13] A.W. Guy. History of Biological Effects and Medical Applications of Microwave Energy. *IEEE Transactions on Microwave Theory and Techniques*, 32(9):1182–1200, September 1984.
- [14] Richard Kovacs. *Electrotherapy and Light Therapy*. Lea and Febiger, Philadelphia, 1945.
- [15] C.C. Johnson and A.W. Guy. Nonionizing electromagnetic wave effects in biological materials and systems. *Proceedings of the IEEE*, 60(6):692–718, 1972.
- [16] David O. Draper, Kenneth Knight, T. Fujiwara, and J. Chris Castel. Temperature Change in Human Muscle During and After Pulsed Short-Wave Diathermy. *Journal of Orthopaedic & Sports Physical Therapy*, 29(1):13–22, January 1999.
- [17] Kristian Overgaard and Jens Overgaard. Investigations on the possibility of a thermic tumour therapy I. *European Journal of Cancer (1965)*, 8(1):65–78, February 1972.
- [18] A. Kramer, J. Lademann, C. Bender, A. Skell, B. Hartmann, S. Munch, P. Hinz, A. Ekkernkamp, R. Matthes, I. Koban, I. Partecke, C.D. Heidecke, K. Masur, S. Reuter, K.D. Weltmann, S. Koch, and O. Assadian. Suitability of tissue tolerable plasmas (TTP) for the management of chronic wounds. *Clinical Plasma Medicine*, 1(1):11–18, June 2013.
- [19] Mihran Kassabian. *Röntgen Rays and Electrotherapeutics*. J.B. Lippincott Company, Philadelphia, PA USA.
- [20] P Oudin. L'Oeuvre Scientifique du Docteur P. Oudin (1851-1923). *Societe Francaise d'Electrotherapie et Radiologie Medicale*, Supplement au bulletin officiel, July 1924.
- [21] G. Isbary, T. Shimizu, J.L. Zimmermann, J. Heinlin, S. Al-Zaabi, M. Rechfeld, G.E. Morfill, S. Karrer, and W. Stolz. Randomized placebo-controlled clinical trial showed cold atmospheric argon plasma relieved acute pain and accelerated healing in herpes zoster. *Clinical Plasma Medicine*, 2(2):50–55, December 2014.
- [22] Hans-Robert Metelmann, Christian Seebauer, Vandana Miller, Alexander Fridman, Georg Bauer, David B. Graves, Jean-Michel Pouvesle, Rico Rutkowski, Matthias Schuster, Sander Bekeschus, Kristian Wende, Kai Masur, Sybille Hasse, Torsten Gerling, Masaru Hori, Hiromasa Tanaka, Eun Ha Choi, Klaus-Dieter Weltmann, Philine Henriette Metelmann, Daniel D. Von Hoff, and Thomas von Woedtke. Clinical experience with cold plasma in the treatment of locally advanced head and neck cancer. *Clinical Plasma Medicine*, 9:6–13, March 2018.
- [23] K-D Weltmann and Th von Woedtke. Plasma medicine: current state of research and medical application. *Plasma Physics and Controlled Fusion*, 59(1):014031, January 2017.
- [24] Georg Daeschlein, Matthias Napp, Sebastian von Podewils, Sebastian Scholz, Andreas Arnold, Steffen Emmert, Hermann Haase, Judith Napp, Romy Spitzmueller, Denis Gmbel, and Michael Jnger. Antimicrobial Efficacy of a Historical High-Frequency Plasma Apparatus in Comparison With 2 Modern, Cold Atmospheric Pressure Plasma Devices. *Surgical Innovation*, 22(4):394–400, August 2015.
- [25] Christine Oudin, P. Application Therapeutique Locale des Courants de Haute Frequence en Gynecologique. *Archives d'lectricit Mdicale*, 287:42, 1910.
- [26] HE Crook. *High Frequency Currents*. Bailliere, Tindall and Cox, London, second edition, 1909.
- [27] R Reeve. Vacuum tube for peripheral stimulation, 1917.
- [28] Christian Seebauer. Cold Atmospheric Plasma for the treatment of Oral Lichen Planus as intraoral precancerous lesion. Greifswald, Germany, March 2018.
- [29] H.P. Schwan and K.R. Foster. RF-field interactions with biological systems: Electrical properties and biophysical mechanisms. *Proceedings of the IEEE*, 68(1):104–113, 1980.
- [30] R Pethig and D B Kell. The passive electrical properties of biological systems: their significance in physiology, biophysics and biotechnology. *Physics in Medicine and Biology*, 32(8):933–970, August 1987.
- [31] Khalil Heileman, Jamal Daoud, and Maryam Tabrizian. Dielectric spectroscopy as a viable biosensing tool for cell and tissue characterization and analysis. *Biosensors and Bioelectronics*, 49:348–359, November 2013.
- [32] R. Kavet, R. A. Tell, and R. G. Olsen. Radiofrequency contact currents: sensory responses and dosimetry. *Radiation Protection Dosimetry*, 162(3):268–279, December 2014.
- [33] Don Gies. Human body impedance model at radio frequencies. pages 1–6. IEEE, May 2016.
- [34] Martin Caon. Voxel-based computational models of real human anatomy: a review. *Radiation and Environmental Biophysics*, 42(4):229–235, February 2004.
- [35] Tomoaki Nagaoka, Soichi Watanabe, Kiyoko Sakurai, Etsuo Kunieda, Satoshi Watanabe, Masao Taki, and Yukio Yamanaka. Development of realistic high-resolution whole-body voxel models of Japanese adult males and females of average height and weight, and application of models to radio-frequency electromagnetic-field dosimetry. *Physics in Medicine and Biology*, 49(1):1–15, January 2004.
- [36] Akimasa Hirata, Toshihiro Nagai, Teruyoshi Koyama, Junya Hattori, Kwok Hung Chan, and Robert Kavet. Dispersive FDTD analysis of induced electric field in human models due to electrostatic discharge. *Physics in Medicine and Biology*, 57(13):4447–4458, July 2012.
- [37] E. Okoniewska, M.A. Stuchly, and M. Okoniewski. Interactions of Electrostatic Discharge With the Human Body. *IEEE Transactions on Microwave Theory and Techniques*, 52(8):2030–2039, August 2004.
- [38] Hanna Hanna, Agnese Denzi, Micaela Liberti, Franck M. Andr, and Lluís M. Mir. Electroporation of Inner and Outer Cell Membranes with Microsecond Pulsed Electric Fields: Quantitative Study with Calcium Ions. *Scientific Reports*, 7(1), December 2017.
- [39] W Hamilton and A Sale. Effects of high electric fields on microorganisms II. Mechanism of action of the lethal effect. *Biochimica et Biophysica Acta (BBA) - General Subjects*, 148(3):789–800, December 1967.
- [40] E. Robert, T. Darny, S. Dozias, S. Iseni, and J. M. Pouvesle. New insights on the propagation of pulsed atmospheric plasma streams: From single jet to multi jet arrays. *Physics of Plasmas*, 22(12):122007, December 2015.
- [41] Chong Liu, Danil Dobrynin, and Alexander Fridman. Uniform and non-uniform modes of nanosecond-pulsed dielectric barrier discharge in atmospheric air: fast imaging and spectroscopic measurements of electric fields. *Journal of Physics D: Applied Physics*, 47(25):252003, June 2014.
- [42] Chelsea M Edelblute, Loree C Heller, Muhammad A Malik, Anna Bulysheva, and Richard Heller. Plasma-activated air mediates plasmid DNA delivery in vivo. *Molecular Therapy - Methods & Clinical Development*, 3:16028, 2016.
- [43] Monika Gelker, Christel C. Miller-Goymann, and Wolfgang Vil. Permeabilization of human stratum corneum and full-thickness skin samples by a direct dielectric barrier discharge. *Clinical Plasma Medicine*, 9:34–40, March 2018.
- [44] Endre J Szili, Jun-Seok Oh, Hideo Fukuhara, Rishabh Bhatia, Nishtha Gaur, Cuong K Nguyen, Sung-Ha Hong, Satsuki Ito, Kotaro Ogawa, Chiaki Kawada, Taro Shuin, Masayuki Tsuda, Mutsuo Furihata, Atsushi Kurabayashi, Hiroshi Furuta, Masafumi Ito, Keiji Inoue, Akimitsu Hatta, and Robert D Short. Modelling the helium plasma jet delivery of reactive species into a 3d cancer tumour. *Plasma Sources Science and Technology*, 27(1):014001, December 2017.
- [45] Th. von Woedtke, H.-R. Metelmann, and K.-D. Weltmann. Clinical Plasma Medicine: State and Perspectives of *in Vivo* Application of Cold Atmospheric Plasma: Clinical Plasma Medicine: State and Perspectives of *in Vivo* Application of Cold Atmospheric Plasma. *Contributions to Plasma Physics*, 54(2):104–117, February 2014.
- [46] Steffen Emmert, Franziska Brehmer, Holger Hnle, Andreas Helmke, Nina Mertens, Raees Ahmed, Dirk Simon, Dirk Wandke, Wolfgang Maus-Friedrichs, Georg Dschlein, Michael P. Schn, and Wolfgang Vil. Atmospheric pressure plasma in dermatology: Ulcus treatment and much more. *Clinical Plasma Medicine*, 1(1):24–29, June 2013.
- [47] G Collet, E Robert, A Lenoir, M Vandamme, T Darny, S Dozias, C Kieda, and J M Pouvesle. Plasma jet-induced tissue oxygenation: potentialities for new therapeutic strategies. *Plasma Sources Science and Technology*, 23(1):012005, February 2014.
- [48] Kiara Heuer, Martin A. Hoffmanns, Erhan Demir, Sabrina Baldus, Christine M. Volkmar, Mirco Rhle, Paul C. Fuchs, Peter Awakowicz, Christoph V. Suschek, and Christian Oplnder. The topical use of non-thermal dielectric barrier discharge (DBD): Nitric oxide related effects on human skin. *Nitric Oxide*, 44:52–60, January 2015.
- [49] Tobias Kisch, Andreas Helmke, Sophie Schleusser, Jungin Song, Eirini Liodaki, Felix Hagen Stang, Peter Mailaender, and Robert Kraemer. Improvement of cutaneous microcirculation by cold atmospheric plasma (CAP): Results of a controlled, prospective cohort study. *Microvascular Research*, 104:55–62, March 2016.
- [50] Tobias Kisch, Sophie Schleusser, Andreas Helmke, Karl Ludwig Mauss, Eike Tilman Wenzel, Benedikt Hasemann, Peter Mailaender, and Robert Kraemer. The repetitive use of non-thermal dielectric barrier discharge plasma boosts cutaneous microcirculatory effects. *Microvascular Research*, 106:8–13, July 2016.

- [51] Mounir Laroussi. Sterilization of Contaminated Matter with Atmospheric Pressure Plasma. *IEEE Transactions on Plasma Science*, 24(3):1188–1191, 1996.
- [52] Vandana Miller, Abraham Lin, Gregory Fridman, Danil Dobrynin, and Alexander Fridman. Plasma Stimulation of Migration of Macrophages: Plasma Stimulation of Migration. *Plasma Processes and Polymers*, 11(12):1193–1197, December 2014.
- [53] Vandana Miller, Abraham Lin, and Alexander Fridman. Why Target Immune Cells for Plasma Treatment of Cancer. *Plasma Chemistry and Plasma Processing*, 36(1):259–268, January 2016.
- [54] ET Connor. A shocking business: The technology and practice of electrotherapeutics in Canada, 1840s to 1940s. *Material Culture Review*, 49:60–70, 1999.
- [55] Professor H Burger. The Doctor, the Quack, and the Appetite of the Public for Magic in Medicine. page 6.
- [56] Lisa Rosner. The Professional Context of Electrotherapy. *Journal of the history of medicine and allied sciences*, 43(1):64–82, 1988.
- [57] C Blondel. La Reconnaissance de l'électricité médicales et ses "machines guérir" par les scientifiques français. (1880-1930). *Annales historiques de l'électricité*, 8:37–51, 2010.
- [58] Frederick F. Strong. Electricity and Life. *The Electrical Experimenter*, page 798, March 1917.